

INSTALLATION AND OPERATING INSTRUCTIONS

Vacuum gripping system

ZGA/ZGB/ZGM

DDOC02397

THE KNOW-HOW FACTORY

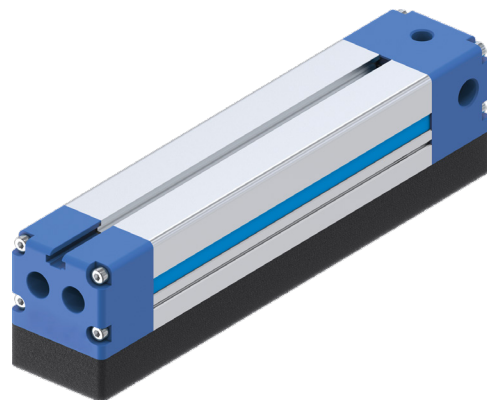

Content

1	Introduction	3
1.1	Supporting documents	3
1.2	Notes and illustrations in the instructions.....	3
1.3	Figures.....	3
2	Safety notices.....	4
3	Proper use	5
4	Personnel qualification	6
4.1	Electricians	6
4.2	Specialists	6
4.3	Instructed personnel.....	6
4.4	Service personnel.....	6
4.5	Additional qualifications	6
5	Product description	7
6	Technical data	7
7	Accessories/scope of delivery	7
7.1	Setting the sensor.....	7
8	Storage	8
9	Installation	8
9.1	Installing the product.....	9
9.2	Installing the power supply	9
10	Operation.....	10
11	Maintenance.....	10
11.1	Spare parts.....	10
11.2	Replacing the sealing foam mat	13
12	Decommissioning/disposal	13
13	Declaration of Incorporation (Machinery Directive)	14
14	Declaration of Incorporation (Machinery Regulation).....	15

1 Introduction

1.1 Supporting documents

NOTICE



Read through the instructions before installing or working with the product.

The instructions contain important notices for your personal safety. They must be read and understood by all persons who work with or handle the product during any phase of the product lifetime.



The documents listed below are available for download on our website www.zimmer-group.com:

- Installation and operating instructions
 - Catalogs, drawings, CAD data, performance data
 - Information on accessories
 - Technical data sheets
 - General Terms and Conditions (GTCs), including warranty information.
- ⇒ Only the documents currently available on the website are valid.

In these instructions, “product” replaces the product designation on the title page.

1.2 Notes and illustrations in the instructions

DANGER



This notice warns of an imminent danger to the life and health of people. Ignoring these notices can lead to serious injury or even death.

- ▶ You absolutely must comply with the described measures for avoiding these dangers.
- ⇒ The warning symbols are assigned according to the type of danger.

WARNING



This notice warns of a situation that is potentially hazardous to personal health. Ignoring these notices can cause serious injury or damage to health.

- ▶ You absolutely must comply with the described measures for avoiding these dangers.
- ⇒ The warning symbols are assigned according to the type of danger.

CAUTION



This notice warns of a situation that is potentially hazardous to people. Ignoring these notices can cause minor, reversible injuries.

- ▶ You absolutely must comply with the described measures for avoiding these dangers.
- ⇒ The warning symbols are assigned according to the type of danger.

NOTICE



This notice warns of possible material or environmental damage. Ignoring these notices can result in damage to the product or the environment.

- ▶ You absolutely must comply with the described measures for avoiding these dangers.
- ⇒ The warning symbols are assigned according to the type of danger.

INFORMATION



This category contains useful tips for handling the product efficiently. Failure to observe these tips will not result in damage to the product. This information does not include any information relevant to health or workplace safety.

1.3 Figures

The figures may deviate from the actual state.

2 Safety notices

CAUTION



Risk of injury and material damage in case of non-compliance

The product is state-of-the-art.

The following are examples of situations in which the product may cause a hazard:

- The product is not properly installed, used or maintained.
- The product is not used for its designated purpose.
- The locally applicable regulations, laws, directives or guidelines are not observed.
- ▶ The product may only be used in accordance with these instructions and the system's technical data. Any changes or additions to the intended use of the product, as well as modifications to the product, such as those in the following examples, require the written permission of the manufacturer:
 - Use of the product under extreme conditions, such as aggressive fluids or abrasive dusts
 - Additional drilled holes or threads
- ⇒ Zimmer Group GmbH accepts no liability for any damage caused by improper use. The operator bears sole responsibility.
- ▶ Perform maintenance tasks, retrofitting or attachment work outside of the machine's danger zone when possible.
- ▶ When using the product under extreme conditions, adjust the maintenance interval according to the degree of soiling.
- ▶ Note that all suction cups release simultaneously, thus releasing the workpiece as soon as the vacuum circuit is interrupted.
- ▶ Ensure sufficient heat dissipation if the product is surrounded by other components or is in continuous operation and adhere to the permissible temperature range.
- ▶ Check the completeness and tightening torques of all mounting screws.

NOTICE



Material damage and malfunction in case of non-compliance

- ▶ Observe the regulations for the vacuum switch and vacuum breaker.

3 Proper use

NOTICE



Material damage and malfunction in case of non-compliance

The product is only to be used in its original state with its original accessories, with no unauthorized changes and within the stipulated parameter limits and operating conditions.

Any other or secondary use is deemed improper.

- ▶ Operate the product only in compliance with the associated instructions.
 - ▶ Operate the product only when it is in a technical condition that corresponds to the guaranteed parameters and operating conditions.
- ⇒ Zimmer Group GmbH accepts no liability for any damage caused by improper use. The operator bears sole responsibility.

- The product must not be operated in an environment that is subjected to vibrations and impacts.
- The product must not be operated in an environment that is subjected to corrosive gases, chemicals, seawater, water or steam.
- The product is intended for industrial use.
- The product is not suited for use in a potentially explosive atmosphere.
- Protection, such as a cover, must be provided in areas exposed to direct sunlight.
- The product must be protected from thermal radiation near heat sources.
- Suitable protective measures must be taken in areas where contact with water, oil or solder may occur.

4 Personnel qualification

WARNING



Injuries and material damage due to inadequate qualification

If inadequately qualified personnel perform work on the product, this can cause serious injuries and significant material damage.

- ▶ All work on the product must be performed by qualified personnel.
- ▶ Before working with the product, read the document in its entirety and make sure that you have understood everything.
- ▶ Observe country-specific accident prevention regulations and the general safety notices.

The following qualifications are a prerequisite for performing various types of work on the product.

4.1 Electricians

Electricians are able to perform work on electrical systems, can recognize and avoid possible dangers and know the relevant standards and provisions due to their technical training, knowledge and experience.

4.2 Specialists

Specialists are able to perform the assigned work, can recognize and avoid possible dangers and know the relevant standards and provisions due to their technical training, knowledge and experience.

4.3 Instructed personnel

Instructed personnel have been trained by the operating company on the tasks and possible dangers of improper behavior.

4.4 Service personnel

Service personnel are able to perform the assigned work and can recognize and avoid possible dangers due to their technical training, knowledge and experience.

4.5 Additional qualifications

Personnel who work with the product must be familiar with the valid safety regulations and laws as well as the standards, guidelines and laws listed in this document.

Personnel who work with the product must have facility-issued authorization to commission, program, configure, operate, maintain and also decommission this product.

5 Product description

The product is used to generate a vacuum.

This allows workpieces to be suctioned and handled.

The figure shows an example product variant of the ZGA series.

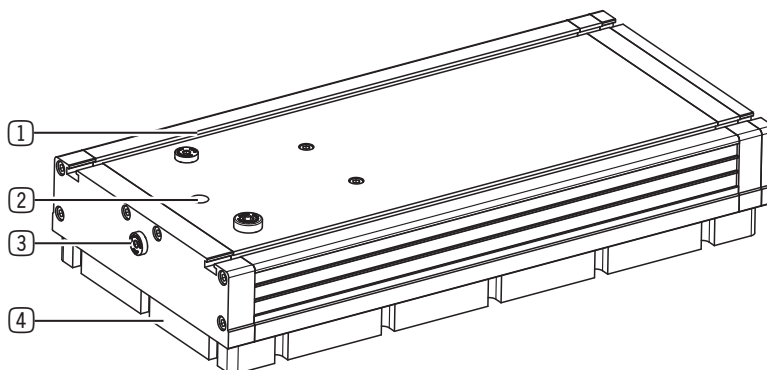

- ① Assembly slot
- ② Pneumatic connection
- ③ Connection for manometer
- ④ Sealing foam mat
- ⑤ Silencer
- ⑥ Blow-off control valve
- ⑦ Air control valve
- ⑧ Vacuum switch

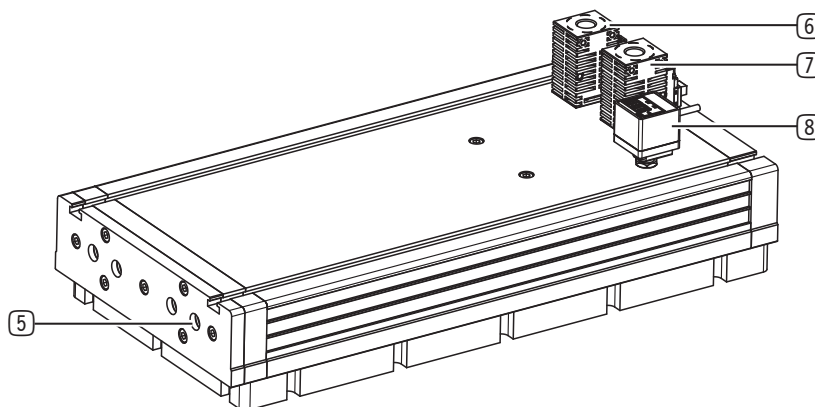

6 Technical data

INFORMATION



- ▶ You can find the information in the technical data sheet on our website.
- This data varies within the series, depending on the specific design.

7 Accessories/scope of delivery

INFORMATION



- If any accessories not sold or authorized by Zimmer Group GmbH are used, the function of the product cannot be guaranteed. The accessories from Zimmer Group GmbH are specifically tailored to the individual products.
- ▶ For information on optional accessories and those included in the scope of delivery, refer to our website.

7.1 Setting the sensor

INFORMATION



- ▶ For further information on setting, refer to our website.
 - Vacuum switch – ZSA

8 Storage

- ▶ Visually inspect all components.
- ▶ Clean all components until all contamination has been removed.
- ▶ Remove potential corrosion spots properly.
- ▶ Seal electrical connections with suitable covers.
- ▶ Seal pneumatic connections with suitable covers.
- ▶ Observe the following points when storing the product for longer periods of time:
 - ▶ Monitor the relative air humidity in the storage area.
 - ▶ Keep the storage location as dust-free and dry as possible.
 - ▶ Observe the temperature range and avoid temperature fluctuations.
 - ▶ Avoid wind, drafts and formation of condensation.
 - ▶ Avoid direct sunlight.

9 Installation

WARNING



Risk of injury due to uncontrolled movement

Risk of injury in case of uncontrolled movements of the machine or system into which the product is to be installed.

- ▶ Switch off the energy supply of the machine before all work.
- ▶ Secure the energy supply against being switched on unintentionally.
- ▶ Check the machine for any residual energy that may be present.

NOTICE



Malfunction in case of non-compliance

- ▶ Make sure that the exhaust air can escape unimpeded.
- ▶ Make sure that there is no grease, water or dirt on the connections.

- ▶ Install the product on an appropriate mounting surface in accordance with the flatness specifications.
- ▶ Make sure that the mounting piece is sufficiently rigid.
- ▶ Ensure the cleanliness of the connection surfaces.
- ▶ Comply with the permitted tightening torques of the mounting screws.

9.1 Installing the product

- ▶ Slide suitable T-slot nuts into the assembly slot.
- ▶ Install the product on the mounting piece by screwing the mounting screws into the T-slot nuts.

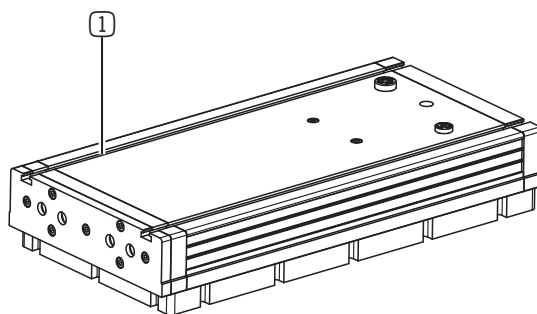

① Assembly slot

9.2 Installing the power supply

NOTICE



Material damage in case of non-compliance

- ▶ You can find the information in the technical data sheet on our website.
- ▶ Keep the supply lines as short as possible and ensure a sufficiently large cross-section.
- ▶ Make sure that the hoses cannot be pinched.

NOTICE



Malfunction in case of non-compliance

An inner diameter that is too small on the compressed-air side results in an insufficient supply of compressed air. Because of this, the maximum output of the system cannot be achieved.

An inner diameter that is too small on the vacuum side results in an increased flow resistance along the hose. This reduces the suction capacity and increases suction times.

An inner diameter that is too large also results in longer suction times due to the larger volume of air to be evacuated.

- ▶ Select the correct screw fittings and pneumatic hoses.

- ▶ Install an optional air control valve or a screw fitting on the pneumatic connection.
- ▶ Install the pneumatic hose.

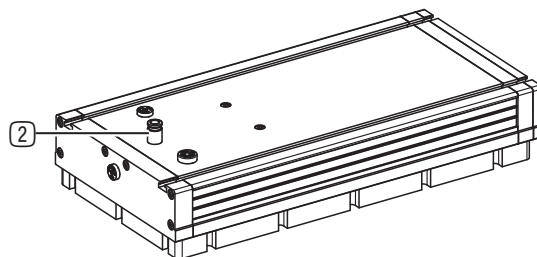
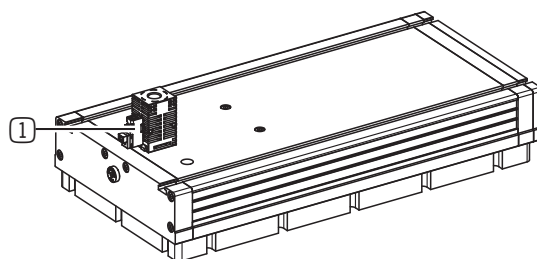

① Air control valve

② Screw fitting

10 Operation

WARNING



Risk of injury caused by falling workpieces

If the suction capacity is insufficient, the workpiece can fall off.

- ▶ Compress the sealing foam mat as much as possible before creating the vacuum.
- ▶ Make sure that no personnel are present underneath the product.

CAUTION



Risk of injury in case of non-compliance

Air streams can injure the eye.

- ▶ Do not look directly into the vacuum openings or into the air streams.
- ▶ Wear protective goggles.

NOTICE



Malfunction in case of non-compliance

- ▶ Make sure that the exhaust air can escape unimpeded.
- ▶ Make sure that there is no grease, water or dirt on the connections.

- ▶ Apply compressed air to the product.

11 Maintenance

- ▶ Note that the product could become damaged under the following circumstances:

- Operation with unauthorized compressed air
- Dirty environment
- Improper use and use that does not comply with the performance data
- Permissible temperature range not observed

- ▶ Visually check the product regularly for damage and dirt.

- ▶ Have maintenance work that requires disassembly of the product and which is not described in these instructions performed by Customer Service only.

⇒ Dismantling and reassembling the product without authorization may result in complications, as special installation equipment is required in some cases. Zimmer Group GmbH accepts no liability for any resulting malfunctions or damage.

11.1 Spare parts

Product	Sealing foam mat part number
ZGB130X220-FS2/FL2	ZGBA-130X220-2
ZGB130X300-FS2/FL2	ZGBA-130X300-2
ZGB130X400-FS2/FL2	ZGBA-130X400-2
ZGB130X600-FS2/FL2	ZGBA-130X600-2
ZGB130X800-FS2/FL2	ZGBA-130X800-2
ZGB130X1000-FS2/FL2	ZGBA-130X1000-2
ZGB130X1200-FS2/FL2	ZGBA-130X1200-2
ZGB130X220-FS1/FL1	ZGBA-130X220-1
ZGB130X300-FS1/FL1	ZGBA-130X300-1
ZGB130X400-FS1/FL1	ZGBA-130X400-1
ZGB130X600-FS1/FL1	ZGBA-130X600-1
ZGB130X800-FS1/FL1	ZGBA-130X800-1
ZGB130X1000-FS1/FL1	ZGBA-130X1000-1
ZGB130X1200-FS1/FL1	ZGBA-130X1200-1
ZGB130X220-FS3/FL3	ZGBA-130X220-3
ZGB130X300-FS3/FL3	ZGBA-130X300-3

ZGB130X400-FS3/FL3	ZGBA-130X400-3
ZGB130X600-FS3/FL3	ZGBA-130X600-3
ZGB130X800-FS3/FL3	ZGBA-130X800-3
ZGB130X1000-FS3/FL3	ZGBA-130X1000-3
ZGB130X1200-FS3/FL3	ZGBA-130X1200-3
ZGA80X150-FS2/FL2	ZGAA-80X150-2
ZGA80X200-FS2/FL2	ZGAA-80X200-2
ZGA80X220-FS2/FL2	ZGAA-80X220-2
ZGA80X250-FS2/FL2	ZGAA-80X250-2
ZGA80X300-FS2/FL2	ZGAA-80X300-2
ZGA130X220-FS2/FL2	ZGAA-130X220-2
ZGA130X300-FS2/FL2	ZGAA-130X300-2
ZGA130X400-FS2/FL2	ZGAA-130X400-2
ZGA130X600-FS2/FL2	ZGAA-130X600-2
ZGA130X800-FS2/FL2	ZGAA-130X800-2
ZGA130X1000-FS2/FL2	ZGAA-130X1000-2
ZGA130X1200-FS2/FL2	ZGAA-130X1200-2
ZGA200X300-FS2/FL2	ZGAA-200X300-2
ZGA200X400-FS2/FL2	ZGAA-200X400-2
ZGA200X600-FS2/FL2	ZGAA-200X600-2
ZGA200X800-FS2/FL2	ZGAA-200X800-2
ZGA200X1000-FS2/FL2	ZGAA-200X1000-2
ZGA200X1200-FS2/FL2	ZGAA-200X1200-2
ZGA300X300-FS2/FL2	ZGAA-300X300-2
ZGA300X400-FS2/FL2	ZGAA-300X400-2
ZGA300X600-FS2/FL2	ZGAA-300X600-2
ZGA300X800-FS2/FL2	ZGAA-300X800-2
ZGA300X1000-FS2/FL2	ZGAA-300X1000-2
ZGA300X1200-FS2/FL2	ZGAA-300X1200-2
ZGA80X150-FS1/FL1	ZGAA-80X150-1
ZGA80X200-FS1/FL1	ZGAA-80X200-1
ZGA80X220-FS1/FL1	ZGAA-80X220-1
ZGA80X250-FS1/FL1	ZGAA-80X250-1
ZGA80X300-FS1/FL1	ZGAA-80X300-1
ZGA130X220-FS1/FL1	ZGAA-130X220-1
ZGA130X300-FS1/FL1	ZGAA-130X300-1
ZGA130X400-FS1/FL1	ZGAA-130X400-1
ZGA130X600-FS1/FL1	ZGAA-130X600-1
ZGA130X800-FS1/FL1	ZGAA-130X800-1
ZGA130X1000-FS1/FL1	ZGAA-130X1000-1
ZGA130X1200-FS1/FL1	ZGAA-130X1200-1
ZGA200X300-FS1/FL1	ZGAA-200X300-1
ZGA200X400-FS1/FL1	ZGAA-200X400-1
ZGA200X600-FS1/FL1	ZGAA-200X600-1
ZGA200X800-FS1/FL1	ZGAA-200X800-1
ZGA200X1000-FS1/FL1	ZGAA-200X1000-1
ZGA200X1200-FS1/FL1	ZGAA-200X1200-1
ZGA300X300-FS1/FL1	ZGAA-300X300-1
ZGA300X400-FS1/FL1	ZGAA-300X400-1

ZGA300X600-FS1/FL1	ZGAA-300X600-1
ZGA300X800-FS1/FL1	ZGAA-300X800-1
ZGA300X1000-FS1/FL1	ZGAA-300X1000-1
ZGA300X1200-FS1/FL1	ZGAA-300X1200-1
ZGM16X60	ZGMA-16X60-2
ZGM16X108	ZGMA-16X108-2
ZGM20X60	ZGMA-20X60-2
ZGM20X108	ZGMA-20X108-2
ZGM40X150-FS2/FL2	ZGMA-40X150-2
ZGM40X200-FS2/FL2	ZGMA-40X200-2
ZGM40X300-FS2/FL2	ZGMA-40X300-2
ZGM40X400-FS2/FL2	ZGMA-40X400-2
ZGM40X500-FS2/FL2	ZGMA-40X500-2
ZGM40X600-FS2/FL2	ZGMA-40X600-2
ZGM50X150-FS2/FL2	ZGMA-50X150-2
ZGM50X200-FS2/FL2	ZGMA-50X200-2
ZGM50X300-FS2/FL2	ZGMA-50X300-2
ZGM50X400-FS2/FL2	ZGMA-50X400-2
ZGM50X500-FS2/FL2	ZGMA-50X500-2
ZGM50X600-FS2/FL2	ZGMA-50X600-2
ZGM40X150-FS1/FL1	ZGMA-40X150-1
ZGM40X200-FS1/FL1	ZGMA-40X200-1
ZGM40X300-FS1/FL1	ZGMA-40X300-1
ZGM40X400-FS1/FL1	ZGMA-40X400-1
ZGM40X500-FS1/FL1	ZGMA-40X500-1
ZGM40X600-FS1/FL1	ZGMA-40X600-1
ZGM50X150-FS1/FL1	ZGMA-50X150-1
ZGM50X200-FS1/FL1	ZGMA-50X200-1
ZGM50X300-FS1/FL1	ZGMA-50X300-1
ZGM50X400-FS1/FL1	ZGMA-50X400-1
ZGM50X500-FS1/FL1	ZGMA-50X500-1
ZGM50X600-FS1/FL1	ZGMA-50X600-1
ZGM40X150-FS3/FL3	ZGMA-40X150-3
ZGM40X200-FS3/FL3	ZGMA-40X200-3
ZGM40X300-FS3/FL3	ZGMA-40X300-3
ZGM40X400-FS3/FL3	ZGMA-40X400-3
ZGM40X500-FS3/FL3	ZGMA-40X500-3
ZGM40X600-FS3/FL3	ZGMA-40X600-3
ZGM50X150-FS3/FL3	ZGMA-50X150-3
ZGM50X200-FS3/FL3	ZGMA-50X200-3
ZGM50X300-FS3/FL3	ZGMA-50X300-3
ZGM50X400-FS3/FL3	ZGMA-50X400-3
ZGM50X500-FS3/FL3	ZGMA-50X500-3
ZGM50X600-FS3/FL3	ZGMA-50X600-3

11.2 Replacing the sealing foam mat

- ▶ Remove the old sealing foam mat by pulling it off the suction plate.
- ▶ Remove any adhesive residues that may be present.
- ▶ Remove the protective film from the new sealing foam.
- ▶ Glue the new sealing foam mat onto the suction plate.
- ▶ Make sure that the hole patterns are exactly on top of each other.

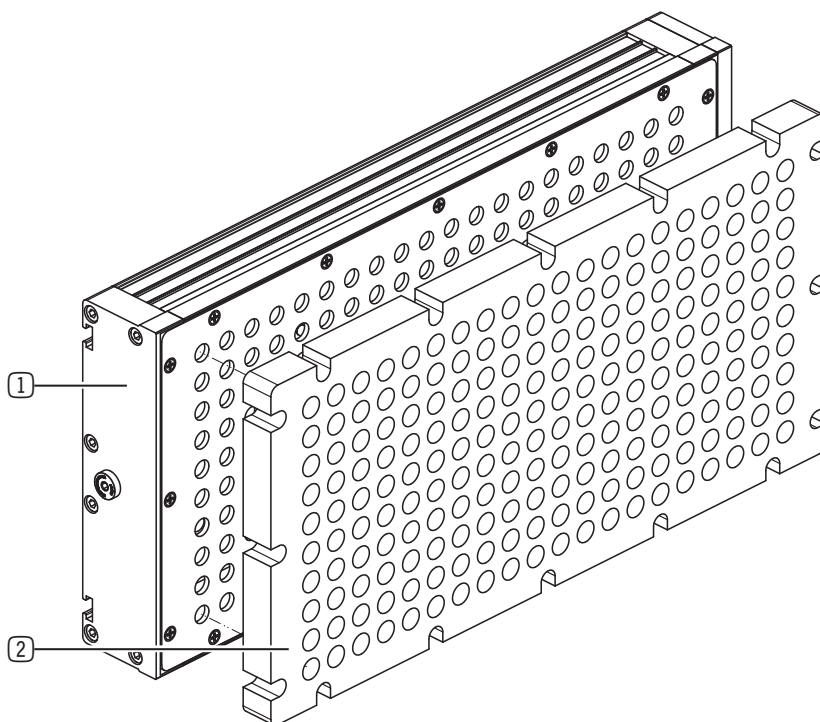

- ① Suction plate
- ② Sealing foam mat

12 Decommissioning/disposal

INFORMATION



When the product reaches the end of its operational phase, it can be completely disassembled and disposed of.

- ▶ Disconnect the product completely from the power supply.
- ▶ Dispose of the components properly according to the material groups.
- ▶ Comply with the locally applicable environmental and disposal regulations.

13 Declaration of Incorporation (Machinery Directive)

In terms of the Machinery Directive 2006/42/EC (Annex II 1 B)

Name and address of the manufacturer:

Zimmer Group GmbH

📍 Am Glockenloch 2
77866 Rheinau, Germany

☎ +49 7844 9138 0

✉ info@zimmer-group.com

🌐 www.zimmer-group.com

We hereby declare that the incomplete machine described below

Product designation: Vacuum gripping system

Type designation: ZGA, ZGB, ZGM

conforms to the requirements of the Machinery Directive, 2006/42/EC, Article 2g, Annex VII B – Annex II B, in its design and the version we put on the market.

The following harmonized standards have been used:

DIN EN ISO 12100 Safety of machinery – General principles for design – Risk assessment and risk reduction

We hereby confirm that all the relevant basic health and safety requirements for the product have been observed and implemented.

A full list of applied standards can be obtained from the manufacturer.

We also declare that the specific technical documents were produced in accordance with Annex VII Part B of this Directive. We undertake to provide the market supervisory bodies with electronic versions of special documents for the incomplete machine through our documentation department, should they have reason to request them.

Commissioning of the incomplete machine is prohibited until it has been found that – where applicable – the machine in which the above-mentioned incomplete machine is to be installed complies with the Machinery Directive (2006/42/EC) and an EC Declaration of Conformity has been drawn up in accordance with Annex II 1 A.

Nicolas Steiger
Authorized representative for
compiling the relevant technical
document

Rheinau, Germany, 2026-01-14
(Place and date of issue)



Martin Zimmer
(Legally binding signature)
Managing Partner

14 Declaration of Incorporation (Machinery Regulation)

In terms of the EU Machinery Regulation 2023/1230, Annex V, Part B

Name and address of the manufacturer:

Zimmer Group GmbH

📍 Am Glockenloch 2
77866 Rheinau, Germany

☎ +49 7844 9138 0

✉ info@zimmer-group.com

🌐 www.zimmer-group.com

We hereby declare that the incomplete machine described below

Product designation: Vacuum gripping system

Type designation: ZGA, ZGB, ZGM

conforms to the requirements of the Regulation 2023/1230, Article 3.10, Annex III, Annex IV Part B, Annex V Part B, in its design and the version we put on the market.

A complete list of the standards applied and the essential safety and health protection requirements is available from the manufacturer.

The incomplete machine may only be commissioned if it has been ascertained, if applicable, that the machine or system in which the incomplete machine is to be installed satisfies the requirements of the EU Machinery Regulation 2023/1230 and an EC Declaration of Conformity has been drawn up in accordance with Annex V, Part A.

Nicolas Steiger

Authorized representative for the compilation of relevant technical documents

Rheinau, Germany, 2027-01-20

(Place and date of issuance)



Martin Zimmer
(Legally binding signature)
Managing Partner