



MATCH

INSTALLATION AND OPERATING INSTRUCTIONS

MATCH robot module

LWR50F

DDOC01074

THE KNOW-HOW FACTORY

Content

1	Supporting documents	5
1.1	Notices and graphics in the installation and operating instructions	5
2	Safety notices	6
3	Proper use	7
4	Personnel qualification	8
4.1	Electricians	8
4.2	Specialists	8
4.3	Instructed personnel.....	8
4.4	Service personnel.....	8
4.5	Additional qualifications	8
5	Product description	9
5.1	Type plate	10
5.2	Product variants and compatibility	10
6	Functional description	11
6.1	LED status display	12
6.2	Connect-LED	12
6.3	Sensors.....	13
6.3.1	Wiring diagram sensor system	14
6.3.2	Adjust the sensors in the inspection position	14
6.3.3	Adjust the sensors in the storage position	14
6.4	Functional safety	15
7	Technical data	15
8	Accessories/scope of delivery	16
9	Transportation/storage/preservation	16
10	Installation	17
10.1	Installing the product.....	18
10.2	Installing the energy supply	19
10.2.1	Installing the pneumatic system	19
10.2.2	Installing the wiring.....	19
10.2.3	Mounting LWR50F-00-01-A.....	20
10.2.4	Mounting LWR50F-00-04-A and LWR50F-00-05-A	20
10.2.5	Mounting LWR50F-01-02-A.....	20
10.2.6	Mounting LWR50F-04-01-A.....	21
10.2.7	Mounting LWR50F-05-02-A.....	21
10.2.8	Mounting LWR50F-06-01-A.....	21
10.2.9	Mounting LWR50F-07-01-A.....	22
10.2.10	Mounting LWR50F-08-01-A.....	22
10.2.11	Mounting LWR50F-09-01-A.....	22
10.2.12	Mounting LWR50F-10-01-A.....	23
10.2.13	Mounting LWR50F-13-01-A.....	23
10.2.14	Mounting LWR50F-13-04-A and LWR50F-13-05-A	24
10.2.15	Mounting LWR50F-14-04-A and LWR50F-14-05-A	24
10.2.16	Mounting LWR50F-15-01-A.....	25
10.2.17	Mounting LWR50F-15-04-A and LWR50F-15-05-A	25
10.2.18	Mounting LWR50F-16-01-A.....	26
10.2.19	Mounting LWR50F-17-01-A.....	26
10.2.20	Mounting LWR50F-17-04-A and LWR50F-17-05-A	27
10.2.21	Mounting LWR50F-18-01-A and LWR50F-01-02-A-01	27
10.2.22	Mounting LWR50F-20-01-A.....	27
10.2.23	Installing LWR50F-20-04-A and LWR50F-20-05-A	28

10.2.24	Mounting LWR50F-21-01-A	28
10.2.25	Installing LWR50F-21-04-A and LWR50F-21-05-A	29
10.2.26	Mounting LWR50F-22-01-A	29
10.2.27	Installing LWR50F-22-04-A and LWR50F-22-05-A	30
10.2.28	Installing LWR50F-25-01-A	30
10.2.29	Installing LWR50F-26-01-A	30
10.3	Static charge	31
10.4	Heat dissipation	31
10.5	Installing accessories	31
11	Operation	31
11.1	Freedrive operation (optional).....	31
12	Maintenance	32
13	Decommissioning/disposal	32
14	RoHS declaration	33
15	REACH declaration	33
16	Declaration of Incorporation	34
17	Declaration of Conformity	35

1 Supporting documents

NOTICE



Read through the installation and operating instructions before installing or working with the product.

The installation and operating instructions contain important notes for your personal safety. They must be read and understood by all persons who work with or handle the product during any phase of the product lifetime.



The documents listed below are available for download on our website www.zimmer-group.com.

- Installation and operating instructions
 - Catalogs, drawings, CAD data, performance data
 - Information on accessories
 - Technical data sheets
 - General Terms and Conditions, including warranty information.
- ⇒ Only those documents currently available on the website are valid.

In these installation and operating instructions, "product" refers to the product designation on the title page!

1.1 Notices and graphics in the installation and operating instructions

DANGER



This notice warns of an imminent danger to the life and health of people. Ignoring these notices can lead to serious injury or even death.

- ▶ You absolutely must comply with the described measures for avoiding these dangers!
- ⇒ The warning symbols are assigned according to the type of danger.

WARNING



This notice warns of a situation that is potentially hazardous to personal health. Ignoring these notices can cause serious injury or damage to health.

- ▶ You absolutely must comply with the described measures for avoiding these dangers!
- ⇒ The warning symbols are assigned according to the type of danger.

CAUTION



This notice warns of a situation that is potentially hazardous to persons. Ignoring these notices can cause minor, reversible injuries.

- ▶ You absolutely must comply with the described measures for avoiding these dangers!
- ⇒ The warning symbols are assigned according to the type of danger.

NOTICE



This notice warns of possible material and environmental damage. Ignoring these notices can result in damage to the product or the environment.

- ▶ You absolutely must comply with the described measures for avoiding these dangers!
- ⇒ The warning symbols are assigned according to the type of danger.

INFORMATION



This category contains useful tips for handling the product efficiently. Failure to observe these tips will not result in damage to the product. This information does not include any information relevant to health or workplace safety.

2 Safety notices

CAUTION



Risk of injury and material damage in case of non-compliance

Installation, commissioning, maintenance and repairs may only be performed by qualified specialists in accordance with these installation and operating instructions.

The product is state-of-the-art.

The following are examples of situations in which the product may cause a hazard:

- The product is not properly installed, used or maintained.
- The product is not used for its designated purpose.
- The locally applicable regulations, laws, directives or guidelines are not observed.
- ▶ The product may only be used in accordance with these installation and operating instructions and the product's technical data. Any changes or additions to the intended use of the product, as well as modifications to the product, such as those in the following examples, require the written permission of the manufacturer:
 - Use of the product under extreme conditions, such as aggressive fluids or abrasive dusts
 - Additional drilled holes or threads
- ⇒ Zimmer GmbH shall accept no liability for any damage caused by improper use. The operator bears sole responsibility.
- ▶ Make sure that the power supply is disconnected before you mount, adjust, modify, maintain or repair the product.
- ▶ Whenever work is carried out on the product, make sure that the product cannot be actuated by mistake.
- ▶ Perform maintenance tasks, renovation work or attachment work outside of the machine's danger zone when possible.
- ▶ Do not reach into the operational range of the product.
- ▶ Always adhere to the required maintenance intervals.
- ▶ When using the product under extreme conditions, adjust the maintenance interval according to the degree of contamination.
- ▶ Check the completeness and tightening torques of all mounting screws.

CAUTION



Notes and handling regulations for electrostatically sensitive components

Electrostatically sensitive components are individual components, integrated circuits or assemblies that can be damaged by electrostatic fields or electrostatic discharge.

- ▶ When handling electrostatic components, make sure that persons, the work area and packaging are all fully grounded.
- ▶ Touch electronic components only in appropriately identified areas with conductive flooring and only if:
 - You are grounded by means of special bracelets.
 - You wear shoes that are suitable and approved for the discharge of electrostatic charges.
- ▶ Do not bring electronic assemblies into contact with plastics and parts of clothing that have plastic content.
- ▶ Store electronic assemblies on conductive underlays only.
- ▶ Do not install electronic assemblies in the vicinity of data back-up devices or monitors (monitor distance > 100 mm).
- ▶ Perform measurements on electronic assemblies only if:
 - The measuring instrument is grounded (e.g. via a ground conductor).
 - The measuring head is momentarily discharged before measuring with a floating measuring instrument.

3 Proper use

NOTICE



Material damage and malfunction in case of non-compliance

The product is only to be used in its original state with its original accessories, with no unauthorized changes and within the stipulated parameter limits and operating conditions.

Any other or secondary use is deemed improper.

- ▶ Operate the product only in compliance with the associated installation and operating instructions.
 - ▶ Operate the product only when it is in a technical condition that corresponds to the guaranteed parameters and operating conditions.
- ⇒ Zimmer GmbH shall accept no liability for any damage caused by improper use. The operator bears sole responsibility.

- The product is designed specifically for (cooperative/collaborative) use on robot systems and in combination with the MATCH quick-change system.
- The product is designed exclusively for electric operation using a 24 V DC power supply.
- The product must always be mounted on materials that dissipate heat.
- The product is intended for industrial use.
- The product is to be used as intended in enclosed rooms for temporary gripping, handling and holding.
- Direct contact with perishable goods/food is not permitted.

4 Personnel qualification

WARNING



Injuries and material damage due to inadequate qualification

If inadequately qualified personnel perform work on the product, this can cause serious injuries and significant material damage.

- ▶ All work on the product must be performed by qualified personnel.
- ▶ Before working with the product, read the document in its entirety and make sure that you have understood everything.
- ▶ Observe country-specific accident prevention regulations and the general safety notices.

The following qualifications are a prerequisite for performing various work on the product.

4.1 Electricians

Electricians are able to perform work on electrical systems, can recognize and avoid possible dangers and know the relevant standards and provisions due to their technical training, knowledge and experience.

4.2 Specialists

Specialists are able to perform the assigned work, can recognize and avoid possible dangers and know the relevant standards and provisions due to their technical training, knowledge and experience.

4.3 Instructed personnel

Instructed personnel have been trained by the operating company on the tasks and possible dangers of improper behavior.

4.4 Service personnel

Service personnel are able to perform the assigned work and can recognize and avoid possible dangers due to their technical training, knowledge and experience.

4.5 Additional qualifications

Persons who work with the product must be familiar with the valid safety regulations and laws as well as the standards, guidelines and laws listed in this document.

Personnel who work with the product must have facility-issued authorization to commission, program, configure, operate, maintain and also decommission this product.

5 Product description

The MATCH End-of-Arm Ecosystem is equipped with an extensive range of functions and universal communication interfaces. MATCH is compatible with all common lightweight robots. The system can be mounted on the robot flange and set up with a few manual adjustments.

The product is a safe quick-change system (MATCH robot module).

The basic and proven safety principles from EN ISO 13849-1 can be complied with only if original parts from Zimmer GmbH are used.

The original parts from Zimmer GmbH required for the safety principles are:

- ① MATCH robot module (LWR50F-xx)
- ② MATCH gripper (LWR50L-xx)
- ③ MATCH storage station (ALWR1-50-A) (sensors optional)

For the overall safety of the function, all three components (MATCH robot module, MATCH gripper, and MATCH storage station) must be taken into account (see "Functional Safety" section).

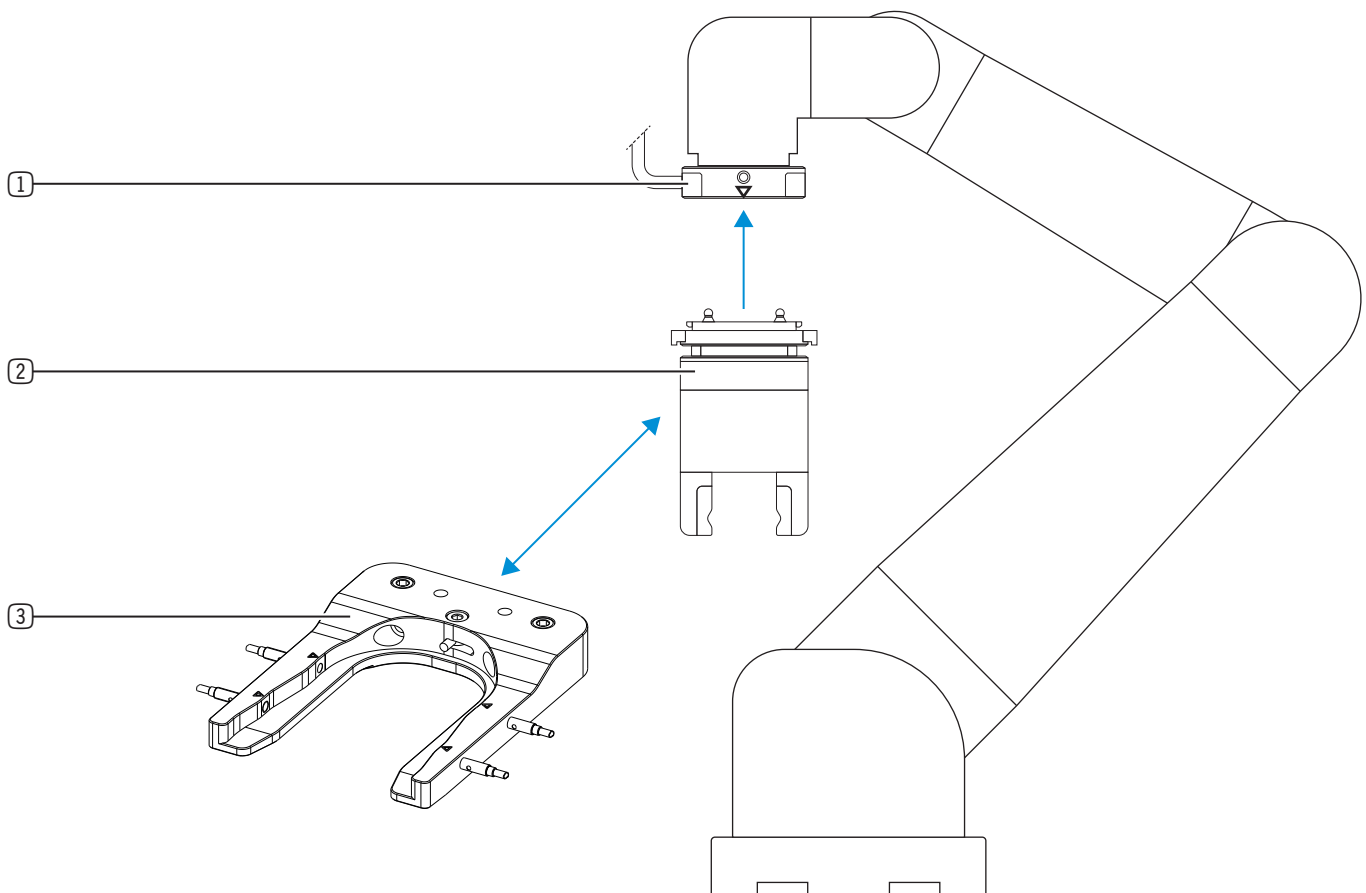

5.1 Type plate

A type plate is attached to the housing of the product.

The article number and confirmation number are shown on the type plate.

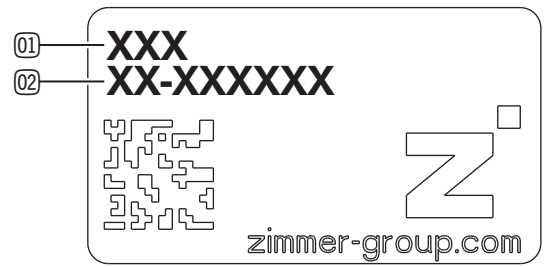

① Article number

② Confirmation number

5.2 Product variants and compatibility

INFORMATION



- ▶ You can find information about product variants and their compatibility on our website.
- ▶ Please contact Customer Service if you have any questions.

6 Functional description

The product is installed on a robot system. It is used to hold an MATCH gripper.

The MATCH gripper automatically locks with the product during automatic extending out of the MATCH storage station; as an alternative, the MATCH gripper can be manually installed on the product.

When the MATCH robot module and MATCH gripper are joined, the internal spring-pin contacts for signal transmission are contacted. Then, the Connect LED changes color from red to green and a Connect signal (depending on the variant) is passed to the higher-level control system.

The product can be operated with a wide variety of MATCH gripper. The prerequisite for this is a compatible MATCH gripper.

Due to the differently sized centering pins and marks on the MATCH gripper, they cannot be installed backwards on the MATCH robot module.

The product has the hot plug function, which enables changing a MATCH gripper while electrified.

The MATCH gripper is designed in such a way that incorrect insertion into the MATCH storage station is impossible.

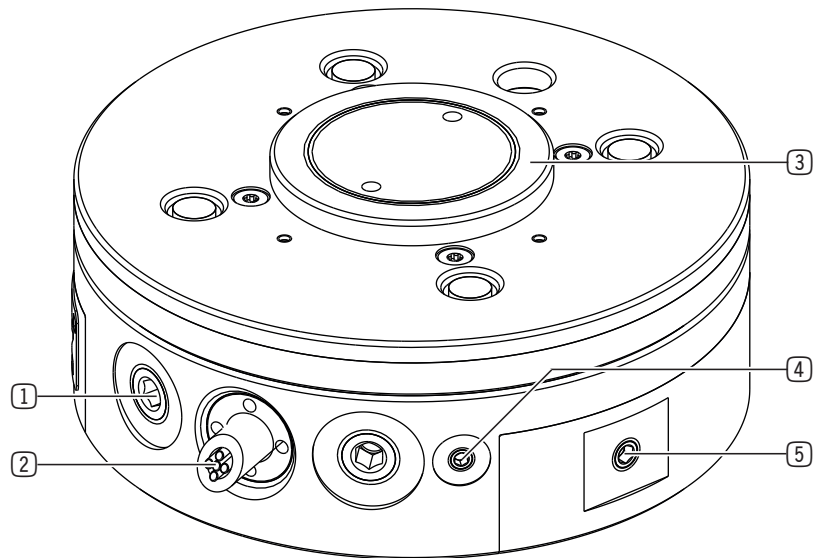

- ① Pneumatic connection
- ② Voltage supply, robot / MATCH robot module
- ③ Positioning/connection
- ④ Grounding
- ⑤ Strain relief
- ⑥ Spring pin contacts
- ⑦ Positioning the MATCH gripper
- ⑧ Pneumatic feedthrough
- ⑨ Connect LED, Freedrive (robot-specific)
- ⑩ Locking
- ⑪ LED ring (optional)

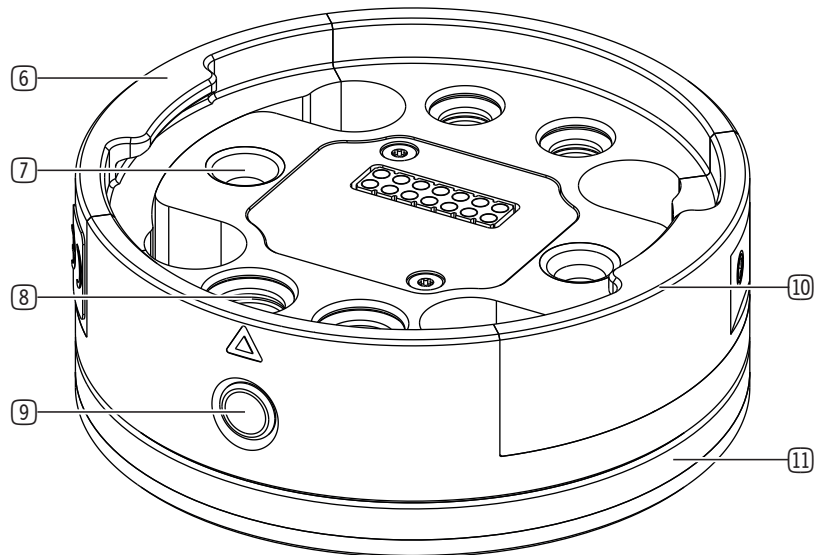

INFORMATION



- ▶ For information about compatible MATCH grippers, refer to our website.
- ▶ Please contact Customer Service if you have any questions.

6.1 LED status display

An LED ring is available for the LWR50F-xx-05-A product.

The colors of the LED ring reflect the status of the IO-Link device in the MATCH gripper with quick-change system. The LED ring enables a 360° status display.

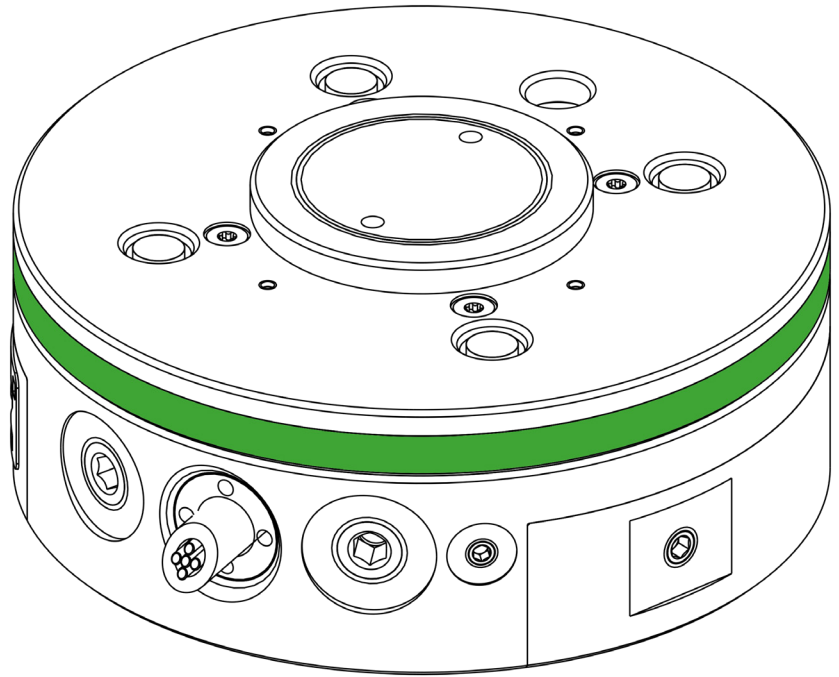

LED state	Function of the Zimmer IO-Link products	Function of the Schmalz IO-Link
None	No supply voltage	No supply voltage
Flashing	No connection to the IO-Link device	No connection to the IO-Link device
Continuous light	An error is present	An error is present
(White) flashing	Unknown IO-Link device	Unknown IO-Link device
Continuous light	-	Warning is present.
Continuous light	Taught-in workpiece gripped	Workpiece vacuumed (vacuum > H2)
Continuous light	Gripper in end position or no taught-in part gripped.	Neutral state (vacuum > H2)

6.2 Connect-LED

LED state	Function of the Zimmer IO-Link products	Function of the Schmalz IO-Link
None	No supply voltage	No supply voltage
Continuous light	No MATCH robot module coupled.	No MATCH robot module coupled.
Continuous light	One MATCH robot module coupled.	One MATCH robot module coupled.

6.3 Sensors

Example image of a combination consisting of a MATCH robot module, MATCH gripper, and MATCH storage station. Check up to two sensors in the storage position to see whether the MATCH gripper is present in the MATCH storage station. Then move the MATCH robot module onto the MATCH gripper from above. The centering pins of the MATCH gripper help in insertion.

The robot, along with the MATCH robot module and MATCH gripper, moves to the inspection position sensors in the MATCH storage station.

The two sensors in the inspection position (test channel) respond if the lockings are extended and make contact in the MATCH robot module.

When the MATCH robot module and MATCH gripper are joined, the internal spring-pin contacts for signal transmission are contacted.

Then the Connect LED changes color from red to green and a Connect signal (depending on the variant) is passed to the higher-level control system.

NOTICE



Non-compliance may result in material damage.

A camera can be mounted on installation size LWR50F-08-01-A. There must be sufficient clearance between the camera and MATCH robot module to prevent collisions. The needed adapter plate is enclosed with the MATCH robot module.

- ▶ Install an adapter plate between the camera and MATCH robot module.

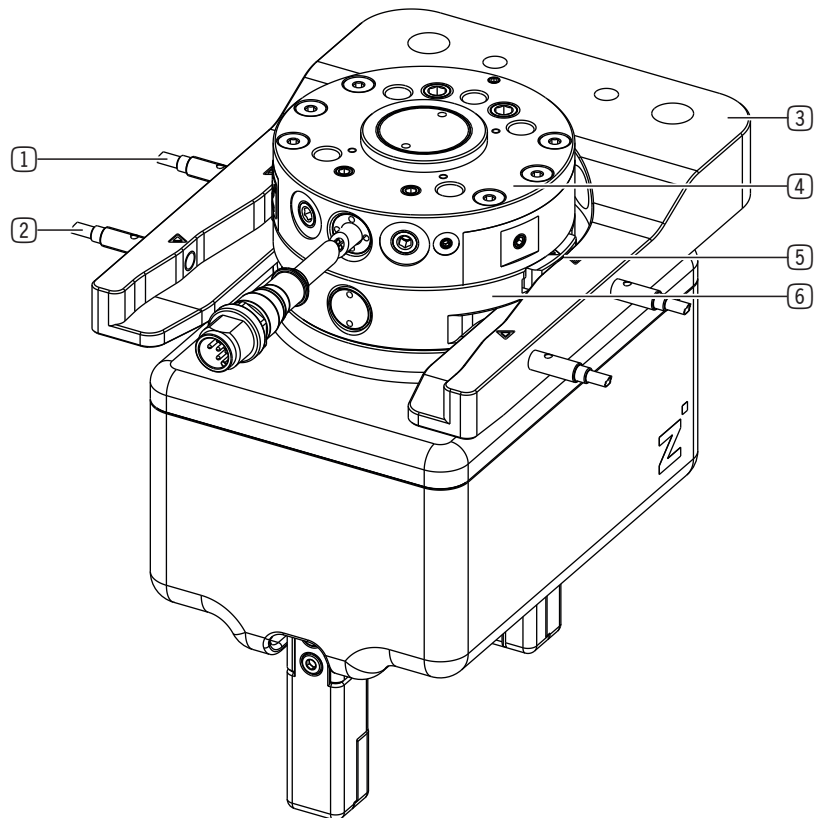

- ① Sensor in storage position (MATCH gripper present)
- ② Sensor in inspection position (test channel, locking extended)
- ③ MATCH storage station
- ④ MATCH robot module for quick-change system
- ⑤ Locking
- ⑥ MATCH gripper for quick-change system

6.3.1 Wiring diagram sensor system

Sensor plug connection M8 3-pin:

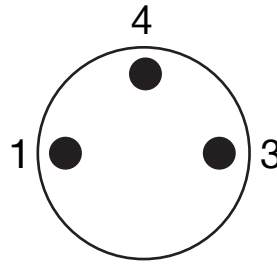

Graphical symbol for sensor in storage position

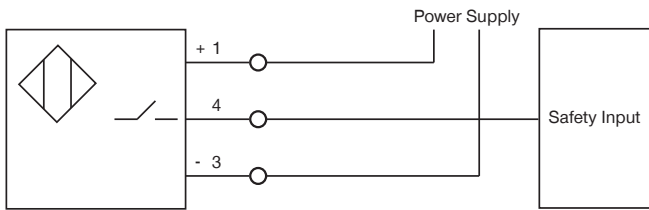

2 sensors in inspection position connected in series

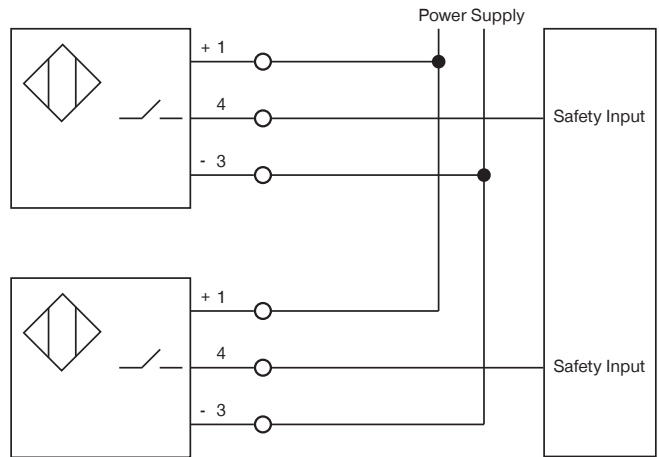

6.3.2 Adjust the sensors in the inspection position

- ▶ Bring the markings on the locking elements of the MATCH gripper to the position of the front markings of the MATCH storage station.
- ▶ Turn in the sensors until they emit a signal.
- ▶ Fasten the sensors at this position.
- ▶ Coat the sensors with sealing lacquer.

6.3.3 Adjust the sensors in the storage position

- ▶ Position an MATCH gripper in the MATCH storage station.
- ▶ Turn in the sensors until they emit a signal.
- ▶ Coat the sensors with sealing lacquer.

- ① Sensor in storage position (MATCH gripper present)
- ② Sensor in inspection position (test channel, locking extended)

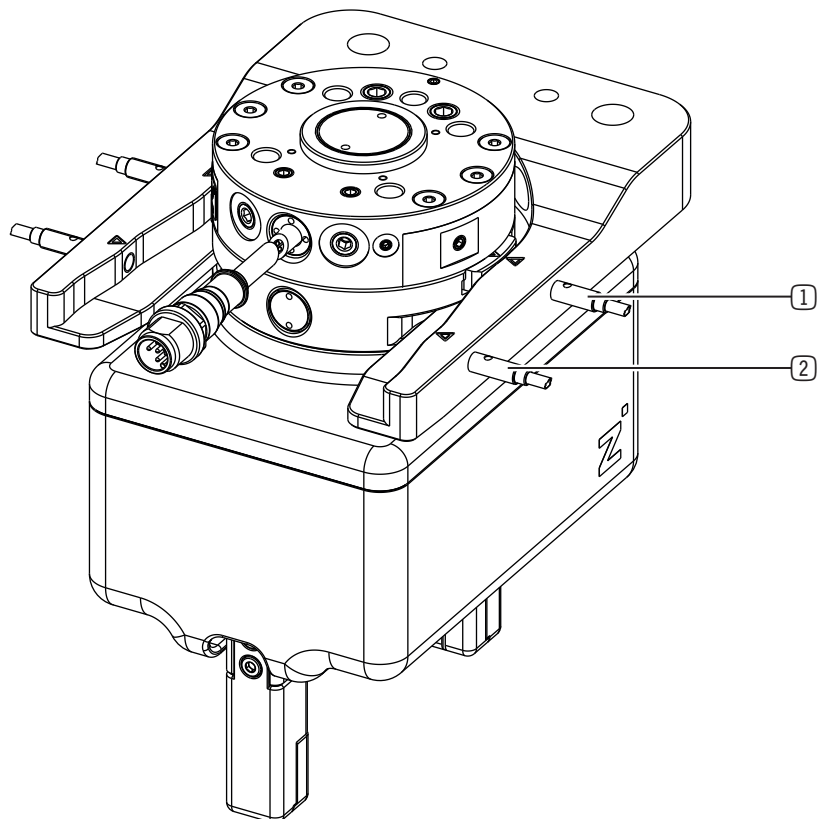

6.4 Functional safety

For the overall safety of the function, all three components (MATCH robot module, MATCH gripper and MATCH storage station) must be taken into account.

The safety function that ensures secure locking between the MATCH robot module and MATCH gripper of the product is implemented via two redundant action channels that consist of a mechanical locking and springs.

Technical supplementary safety measures (sensors) provide a high degree of diagnostic coverage. The product can thus be classified into control category 3 in accordance with Chapter 6.2.6 of DIN EN ISO 13849-1. According to Figure 5, Chapter 4.5.4 of the specified standard, the PL d can be achieved with this product.

Fault elimination in accordance with DIN EN ISO 13849-2, Annex A, Table A2 and A3 for the helical compression springs used can be given.

7 Technical data

INFORMATION



- ▶ You can find the information in the technical data sheet on our website.
- This data varies within the series, depending on the specific design.
- ▶ Please contact Customer Service if you have any questions.

8 Accessories/scope of delivery

INFORMATION



If any accessories not sold or authorized by Zimmer GmbH are used, the function of the product cannot be guaranteed. Zimmer GmbH accessories are specifically tailored to the individual products.

- ▶ For optional accessories and those included in the scope of delivery, refer to our website.

9 Transportation/storage/preservation

- ▶ Transport and storage of the product must be done only with the original packaging.
- ▶ If the product has already been installed on the superordinate machine unit, care must be taken during transport to ensure that no unexpected movements can occur.
 - ▶ Before commissioning the product and after transport, check all power and communication connections as well as all mechanical connections.
- ▶ If the product is stored for an extended period, the following points are to be observed:
 - ▶ Keep the storage location as dust-free and dry as possible.
 - ▶ Avoid temperature fluctuations.
 - ▶ Avoid wind/drafts/water condensation formation.
 - ▶ Pack the product and do not expose it to direct sunlight during storage.
- ▶ Clean all components. There must be no soiling left on the components.
- ▶ Visually inspect all components.
- ▶ Remove all foreign substances.
- ▶ Properly remove potential corrosion spots.
- ▶ Close electrical connections using suitable covers.

10 Installation

WARNING



Risk of injury due to uncontrolled movements

Risk of injury in case of unexpected movement of the machine or system into which the product is to be installed.

- ▶ Switch off the energy supply of the machine before any work.
- ▶ Secure the power supply against being switched on unintentionally.
- ▶ Check the machine for any residual energy that may be present.

CAUTION



Risk of injury due to uncontrolled movements

Risk of injury in the event of uncontrolled movement of the product when the power supply is connected.

- ▶ Switch off the power supply to the machine before carrying out any work.
- ▶ Secure the power supply against being switched on unintentionally.
- ▶ Check the machine for any residual energy that may be present.

NOTICE



Non-compliance may result in material damage.

Installation may only be carried out by qualified personnel in accordance with these installation and operating instructions.

- ▶ Switch off the power supply before any assembly, installation or maintenance work.

Assembly requirements

Permissible unevenness [mm]	0,03
Strength class (DIN EN ISO 4762)	8.8

INFORMATION



Further installation information:

- The mounting screws are not included in the scope of delivery.

- ▶ Make sure that the mounting surface of the product and connection structure are clean (product grounding).
- ▶ Install the product on an appropriate mounting surface in accordance with the flatness specifications.
- ▶ Make sure that the mounting piece is sufficiently rigid.
- ▶ Please note the permitted tightening torques of the mounting screws at www.zimmer-group.com/de/td.

10.1 Installing the product

- ▶ Insert the product into the robot arm by the connection.
- ▶ Loosely attach the mounting screws.
- ▶ Tighten the mounting screws crosswise.

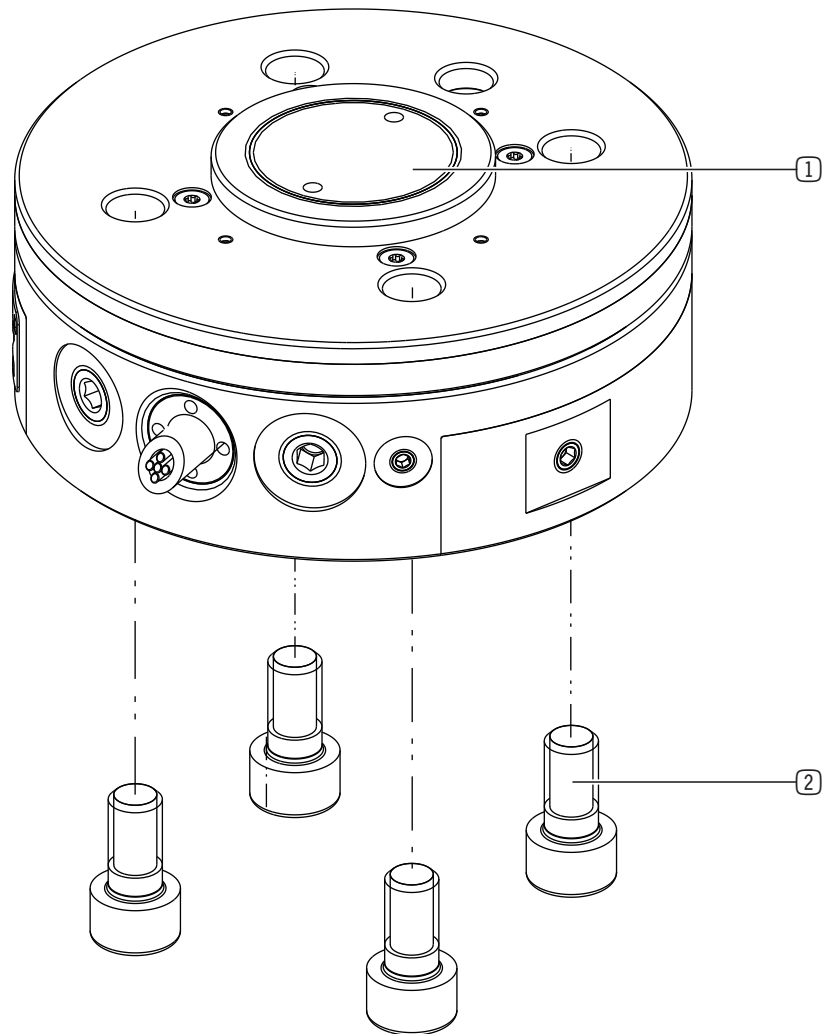

- ① Connection
- ② Mounting screw

10.2 Installing the energy supply

10.2.1 Installing the pneumatic system

- ▶ Unscrew the grub screws.
- ▶ Mount the screw fittings in the provided connections.

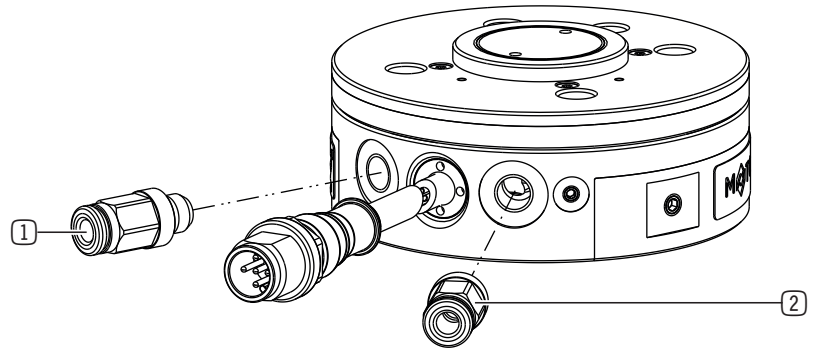

- ① Close gripper
- ② Open gripper

10.2.2 Installing the wiring

CAUTION



Risk of injury from getting caught in the connecting cable

While the robot is moving, hair or limbs can be caught in the connecting cable.

- ▶ Route the connecting cable as close as possible to the robot arm.
- ▶ Avoid the danger zone.

NOTICE



Non-compliance may result in material damage.

The cable mounted on the product can be subjected to a torsional angle of +50°.

- ▶ Do not route the cable so that it is strained.
 - ▶ You must meet the minimum bending radius of 10x the outer diameter.
 - ▶ Secure free-hanging cables to prevent excessive motion loads or pinching.
 - ▶ The contacts of the energy supply must be dry, clean and undamaged at all times.
- ⇒ Damage to the contacts can result in malfunction of the product.

- ▶ Connect the product to the robot control system or route the connecting cable along the robot to the IO-Link master.

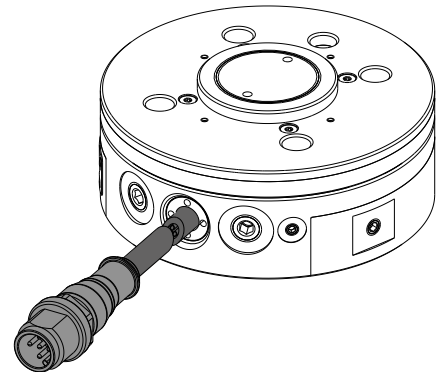

10.2.3 Mounting LWR50F-00-01-A

pin	Color	Function	Explanation
1	White	Analog output	Jaw position 0–10 V DC
2	Brown	Digital output 3	Connect signal: 24 V DC if MATCH gripper is coupled.
3	Green	Digital output 2	WorkPosition (jaws inward)
4	Yellow	Digital output 1	BasePosition (jaws outward)
5	Gray	PWR	24 V DC supply voltage
6	Pink	Digital input 1	Inward move command: Jaws move inward
7	Blue	Digital input 2	Outward move command: Jaws move outward
8	Red	GND	0 V DC supply voltage

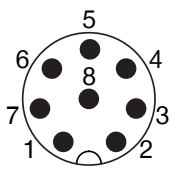

M8 8-pin plug

The inputs of the product are configured for 24 V DC PNP outputs of the control system.

10.2.4 Mounting LWR50F-00-04-A and LWR50F-00-05-A

Activation is done via SCM or a commercially available IO-Link master with Port Class B.

pin	Color	Function	Explanation
1	Brown	24 V DC sensor	24 V DC supply voltage for IO-Link communication
2	White	PWR actuator	24 V DC supply voltage for actuator
3	Blue	GND sensor	0 V DC supply voltage for IO-Link communication
4	Black	C/Q	IO-Link communication
5	Gray	GND actuator	0 V DC supply voltage for actuator

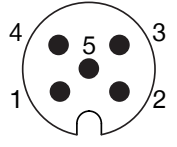

M12, 5-pin Connector/bracket

10.2.5 Mounting LWR50F-01-02-A

pin	Color	Function	Explanation
1	White	Analog output	0 to 10 V DC output
2	Brown	Digital output 3	Connect signal: 24 V DC if MATCH gripper is coupled.
3	Green	Digital output 2	WorkPosition (jaws inward)
4	Yellow	Digital output 1	BasePosition (jaws outward)/Freedrive: Either a digital output or the Freedrive signal can be evaluated. Freedrive signal: 24 V DC, if Freedrive button is pressed.
5	Gray	PWR	24 V DC supply voltage
6	Pink	Digital input 1	Inward move command: Jaws move inward
7	Blue	Digital input 2	Outward move command: Jaws move outward
8	Red	GND	0 V DC supply voltage

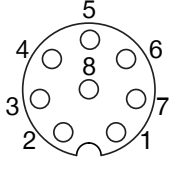

M8, 8-pin Socket/bracket

The inputs of the product are configured for NPN outputs of the control system.

10.2.6 Mounting LWR50F-04-01-A

pin	Color	Function	Explanation
1	White	PWR	24 V DC supply voltage
2	Brown	Digital output 2	WorkPosition (jaws inward)
3	Green	Digital output 1	BasePosition (jaws outward)
4	Yellow	Digital output 3	Connect signal: 24 V DC if MATCH gripper is coupled.
5	Gray	Digital input 1	Inward move command: Jaws move inward
6	Pink	Digital input 2	Outward move command: Jaws move outward
7	-	-	-
8	Red	GND	0 V DC supply voltage

M8, 8-pin Connector/bracket

The inputs of the product are configured for NPN outputs of the control system.

10.2.7 Mounting LWR50F-05-02-A

pin	Color	Function	Explanation
1	White	GND	0 V DC supply voltage
2	Brown	PWR	24 V DC supply voltage
3	Green	Digital input 2	Outward move command: Jaws move outward
4	Yellow	Digital input 1	Inward move command: Jaws move inward
5	Gray	Digital output 1	BasePosition (jaws outward)
6	-	-	-
7	Blue	Digital output 3	Connect signal: 24 V DC if MATCH gripper is coupled.
8	Red	Analog output	Jaw position 0–10 V DC

M8, 8-pin Connector/bracket

The inputs of the product are configured for NPN outputs of the control system.

10.2.8 Mounting LWR50F-06-01-A

pin	Color	Function	Explanation
1	White	PWR	24 V DC supply voltage
2	Brown	Digital output 1	BasePosition (jaws outward)
3	Green	Digital output 2	WorkPosition (jaws inward)
4	Yellow	Digital input 1	Inward move command: Jaws move inward
5	Gray	Digital input 2	Outward move command: Jaws move outward
6	Pink	Analog output	Jaw position 0–10 V DC
7	Blue	GND	Analog GND
8	Red	GND	0 V DC supply voltage

M8 8-pin plug

The inputs of the product are configured for NPN outputs of the control system.

10.2.9 Mounting LWR50F-07-01-A

pin	Color	Function	Explanation
1	White	Analog output	Jaw position 0–10 V DC
2	Brown	Digital output 3	Connect signal: 24 V DC if MATCH gripper is coupled.
3	Green	Digital output 2	WorkPosition (jaws inward)
4	Yellow	Digital output 1	BasePosition (jaws outward)
5	Gray	PWR	24 V DC supply voltage
6	Pink	Digital input 1	Inward move command: Jaws move inward
7	Blue	Digital input 2	Outward move command: Jaws move outward
8	Red	GND	0 V DC supply voltage

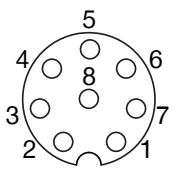

M8, 8-pin Socket/bracket

The inputs of the product are configured for NPN outputs of the control system.

10.2.10 Mounting LWR50F-08-01-A

pin	Color	Function	Explanation
1	White	GND	0 V DC supply voltage
2	Brown	PWR	24 V DC supply voltage
3	Green	Digital input 2	Outward move command: Jaws move outward
4	Yellow	Digital input 1	Inward move command: Jaws move inward
5	-	-	-
6	-	-	-
7	Blue	Digital output 2	WorkPosition (jaws inward)
8	Red	Digital output 1	BasePosition (jaws outward)

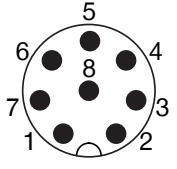

M12, 8-pin Connector/bracket

The inputs of the product are configured for 24 V DC PNP outputs of the control system.

10.2.11 Mounting LWR50F-09-01-A

pin	Color	Function	Explanation
1	White	Analog output	Jaw position 0–10 V DC
2	Brown	Digital output 3	Connect signal: 24 V DC if MATCH gripper is coupled.
3	Green	Digital output 2	WorkPosition (jaws inward)
4	Yellow	Digital output 1	BasePosition (jaws outward)
5	Gray	PWR	24 V DC supply voltage
6	Pink	Digital input 1	Inward move command: Jaws move inward
7	Blue	Digital input 2	Outward move command: Jaws move outward
8	Red	GND	0 V DC supply voltage

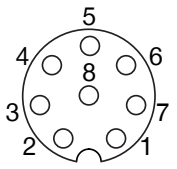

M8, 8-pin Socket/bracket

The inputs of the product are configured for 24 V DC PNP outputs of the control system.

10.2.12 Mounting LWR50F-10-01-A

pin	Color	Function	Explanation
1	White	Digital output 1	BasePosition (jaws outward)
2	Brown	Digital input 1	Inward move command: Jaws move inward
3	Green	Digital input 2	Outward move command: Jaws move outward
4	-	-	-
5	Gray	PWR	24 V DC supply voltage
6	-	-	-
7	Blue	Digital output 2	WorkPosition (jaws inward)
8	Red	GND	0 V DC supply voltage

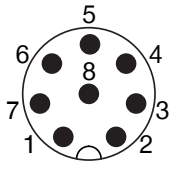

M8, 8-pin Connector/bracket

The inputs of the product are configured for 24 V DC PNP outputs of the control system.

10.2.13 Mounting LWR50F-13-01-A

INFORMATION



Optionally, the ZUB000034 connecting cable is available as a connecting line for the ABB GoFa for OmniCore C30 control system.

► You can find information on our website.

pin	Color	Function	Explanation
1	Brown	PWR	24 V DC supply voltage
3	Blue	GND	0 V DC supply voltage
4	-	-	-

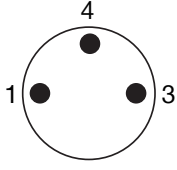

M8, 3-pin Connector/bracket

pin	Color	Function	Explanation
1	Brown	Digital input 2	Outward move command: Jaws move outward
2	White	Digital output 1	BasePosition (jaws outward)
3	Blue	Digital output 2	WorkPosition (jaws inward)
4	Black	Digital input 1	Inward move command: Jaws move inward

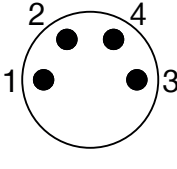

M8, 4-pin Connector/bracket

The inputs of the product are configured for 24 V DC PNP outputs of the control system.

10.2.14 Mounting LWR50F-13-04-A and LWR50F-13-05-A

Activation is done via SCM or a commercially available IO-Link master with Port Class B.

pin	Color	Function	Explanation
1	Brown	PWR actuator	Actuator supply voltage
3	Blue	GND actuator	0 V DC supply voltage for actuator
4	-	-	-

M8, 3-pin Connector/bracket

pin	Color	Function	Explanation
1	Brown	24 V DC sensor	24 V DC supply voltage for IO-Link communication
2	White	C/Q 2	IO-Link communication
3	Blue	GND sensor	0 V DC supply voltage for IO-Link communication
4	Black	C/Q 1	IO-Link communication

M8, 4-pin Connector/bracket

10.2.15 Mounting LWR50F-14-04-A and LWR50F-14-05-A

Activation is done via SCM or a commercially available IO-Link master with Port Class B.

pin	Color	Function	Explanation
1	-	-	-
2	-	-	-
3	-	-	-
4	-	-	-
5	Pink	24 V DC sensor	24 V DC supply voltage for IO-Link communication
6	Yellow	PWR actuator	24 V DC supply voltage for actuator
7	Black	C/Q	IO-Link communication
8	Gray	GND sensor and actuator	0 V DC sensor and actuator supply voltage
9	-	-	-
10	-	-	-
11	-	-	-
12	-	-	-

M12, 12-pin Connector straight

10.2.16 Mounting LWR50F-15-01-A

pin	Color	Function	Explanation
1	Brown	PWR	24 V DC supply voltage
2	Blue	Digital input 2	Outward move command: Jaws move outward
3	White	GND	0 V DC supply voltage
4	Green	Digital input 1	Inward move command: Jaws move inward
5	Pink	Analog output	Jaw position 0–10 V DC
6	Yellow	Digital output 3	Connect signal: 24 V DC if MATCH gripper is coupled.
7	Black	Digital output 1	BasePosition (jaws outward)
8	Gray	Digital output 2	WorkPosition (jaws inward)
9	-	-	-
10	-	-	-
11	-	-	-
12	-	-	-

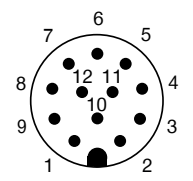

M12, 12-pin Connector straight

The inputs of the product are configured for 24 V DC PNP outputs of the control system.

10.2.17 Mounting LWR50F-15-04-A and LWR50F-15-05-A

Activation is done via SCM or a commercially available IO-Link master with Port Class B.

pin	Color	Function	Explanation
1	Brown	24 V DC sensor	24 V DC supply voltage for IO-Link communication
2	Blue	PWR actuator	24 V DC supply voltage for actuator
3	White	GND sensor	0 V DC supply voltage for IO-Link communication
4	Green	C/Q	IO-Link communication
5	-	-	-
6	-	-	-
7	-	-	-
8	Gray	GND actuator	0 V DC actuator supply voltage
9	-	-	-
10	-	-	-
11	-	-	-
12	-	-	-

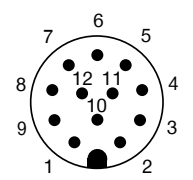

M12, 12-pin Connector straight

10.2.18 Mounting LWR50F-16-01-A

pin	Color	Function	Explanation
1	-	-	-
2	White	Digital output 2	WorkPosition (jaws inward)
3	-	-	-
4	Black	Digital output 1	BasePosition (jaws outward)

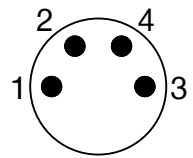

M8, 4-pin Connector/bracket

pin	Color	Function	Explanation
1	Brown	PWR	24 V DC supply voltage
2	White	Digital input 1	Inward move command: Jaws move inward
3	Blue	GND	0 V DC supply voltage
4	Black	Digital input 2	Outward move command: Jaws move outward

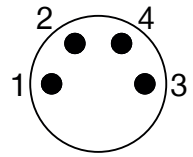

M8, 4-pin Connector/bracket

The inputs of the product are configured for 24 V DC PNP outputs of the control system.

10.2.19 Mounting LWR50F-17-01-A

pin	Color	Function	Explanation
1	-	-	-
2	Brown	Digital output 3	Connect signal: 24 V DC if MATCH gripper is coupled.
3	Green	Digital output 1	WorkPosition (jaws inward)
4	Yellow	Digital output 1	BasePosition (jaws outward)
5	Gray	PWR	24 V DC supply voltage
6	Pink	Digital input 1	Inward move command: Jaws move inward
7	Blue	Digital input 2	Outward move command: Jaws move outward
8	Red	GND	0 V DC supply voltage

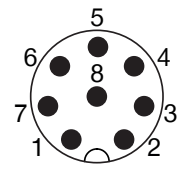

M8, 8-pin Connector/bracket

The inputs of the product are configured for 24 V DC PNP outputs of the control system.

10.2.20 Mounting LWR50F-17-04-A and LWR50F-17-05-A

pin	Color	Function	Explanation
1	White	STO 2	Torque off input 2
2	Brown	STO GND	Torque off GND
3	Green	C/Q	IO-Link communication
4	Yellow	STO 1	Torque off input 1
5	Gray	24 V DC sensor	24 V DC supply voltage for IO-Link communication
6	Pink	PWR actuator	24 V DC supply voltage for actuator
7	Blue	GND actuator	0 V DC supply voltage for actuator
8	Red	GND sensor	0 V DC supply voltage for IO-Link communication

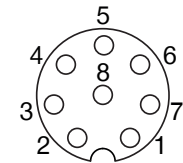

M8, 8-pin Socket/bracket

10.2.21 Mounting LWR50F-18-01-A and LWR50F-01-02-A-01

pin	Color	Function	Explanation
1	Red	GND	0 V DC supply voltage
2	Brown	Digital input 1	Inward move command: Jaws move inward
3	Green	Digital input 2	Outward move command: Jaws move outward
4	Yellow	Digital output 1	BasePosition (jaws outward)
5	Gray	Digital output 2	WorkPosition (jaws inward)
6	Pink	Analog output	Jaw position 0–10 V DC
7	-	-	-
8	-	-	-
9	-	-	-
10	Blue	PWR	24 V DC supply voltage
11	-	-	-
12	-	-	-

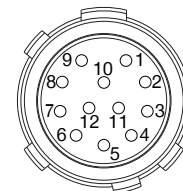

HR10A-10P-12S, 12-pin Socket

The inputs of the product are configured for NPN outputs of the control system.

10.2.22 Mounting LWR50F-20-01-A

pin	Color	Function	Explanation
1	White	Digital input 2	Outward move command: Jaws move outward
2	Brown	Digital input 1	Inward move command: Jaws move inward
3	Green	Digital output 3	Connect signal: 24 V DC if MATCH gripper is coupled.
4	-	-	-
5	Gray	Digital output 1	BasePosition (jaws outward)
6	Pink	Digital output 2	WorkPosition (jaws inward)
7	Blue	PWR	24 V DC supply voltage
8	Red	GND	0 V DC supply voltage

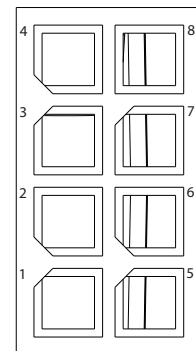

0430200801 8-pin Socket

The inputs of the product are configured for 24 V DC PNP outputs of the control system.

10.2.23 Installing LWR50F-20-04-A and LWR50F-20-05-A

Activation is done via SCM or a commercially available IO-Link master with Port Class B.

pin	Color	Function	Explanation
1	White	24 V DC sensor	24 V DC supply voltage for IO-Link communication
2	Brown	GND sensor	0 V DC supply voltage for IO-Link communication
3	Green	C/Q	IO-Link communication
4	-	-	-
5	-	-	-
6	-	-	-
7	Blue	PWR actuator	24 V DC supply voltage for actuator
8	Red	GND actuator	0 V DC supply voltage for actuator

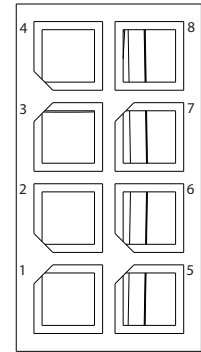

0430200801 8-pin Socket

10.2.24 Mounting LWR50F-21-01-A

pin	Color	Function	Explanation
1	Brown	PWR	24 V DC supply voltage
2	Blue	Digital input 2	Outward move command: Jaws move outward
3	White	GND	0 V DC supply voltage
4	Green	Digital input 1	Inward move command: Jaws move inward
5	Pink	Analog output	Jaw position 0–10 V DC
6	Yellow	Digital output 3	Connect signal: 24 V DC if MATCH gripper is coupled.
7	Black	Digital output 1	BasePosition (jaws outward)
8	Gray	Digital output 2	WorkPosition (jaws inward)
9	-	-	-
10	-	-	-
11	-	-	-
12	-	-	-

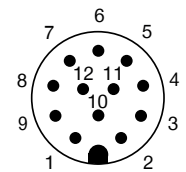

M12, 12-pin Connector straight

The inputs of the product are configured for 24 V DC PNP outputs of the control system.

10.2.25 Installing LWR50F-21-04-A and LWR50F-21-05-A

Activation is done via SCM or a commercially available IO-Link master with Port Class B.

pin	Color	Function	Explanation
1	Brown	PWR actuator	24 V DC supply voltage for actuator
2	Blue	24 V DC sensor	24 V DC supply voltage for IO-Link communication
3	White	GND actuator	0 V DC supply voltage for actuator
4	Green	C/Q	IO-Link communication
5	Pink	GND sensor	0 V DC supply voltage for IO-Link communication
6	-	-	-
7	-	-	-
8	-	-	-
9	-	-	-
10	-	-	-
11	-	-	-
12	-	-	-

M12, 12-pin Connector straight

10.2.26 Mounting LWR50F-22-01-A

pin	Color	Function	Explanation
1	-	-	-
2	-	-	-
3	-	-	-
4	-	-	-
5	Pink	PWR	24 V DC supply voltage
6	Yellow	GND	0 V DC supply voltage
7	Black	Digital input 1	Inward move command: Jaws move inward
8	Gray	Digital input 2	Outward move command: Jaws move outward
9	Red	Digital output 1	BasePosition (jaws outward)
10	Violet	Digital output 2	WorkPosition (jaws inward)
11	Gray/pink	Analog output	Jaw position 0–10 V DC
12	Red/blue	Digital output 3	Connect signal: 24 V DC if MATCH gripper is coupled.

M12, 12-pin Connector straight

The inputs of the product are configured for 24 V DC PNP outputs of the control system.

10.2.27 Installing LWR50F-22-04-A and LWR50F-22-05-A

Activation is done via SCM or a commercially available IO-Link master with Port Class B.

pin	Color	Function	Explanation
1	-	-	-
2	-	-	-
3	-	-	-
4	-	-	-
5	Pink	PWR actuator	24 V DC supply voltage for actuator
6	Yellow	GND actuator	0 V DC supply voltage for actuator
7	Black	C/Q	IO-Link communication
8	Gray	24 V DC sensor	24 V DC supply voltage for IO-Link communication
9	Red	GND sensor	0 V DC supply voltage for IO-Link communication
10	-	-	-
11	-	-	-
12	-	-	-

M12, 12-pin Connector straight

10.2.28 Installing LWR50F-25-01-A

pin	Color	Function	Explanation
1	White	Analog output	Jaw position 0–10 V DC
2	-	-	-
3	Green	Digital output 2	WorkPosition (jaws inward)
4	Yellow	Digital output 1	BasePosition (jaws outward)
5	Gray	PWR	24 V DC supply voltage
6	Pink	Digital input 1	Inward move command: Jaws move inward
7	Blue	Digital input 2	Outward move command: Jaws move outward
8	Red	GND	0 V DC supply voltage

M8, 8-pin Socket/bracket

The inputs of the product are configured for 24 V DC PNP outputs of the control system.

10.2.29 Installing LWR50F-26-01-A

pin	Color	Function	Explanation
1	-	-	-
2	-	-	-
3	-	-	-
4	Yellow	Analog output	Jaw position 0–10 V DC
5	Gray	PWR	24 V DC supply voltage
6	Pink	Digital input 1	Inward move command: Jaws move inward
7	Blue	Digital input 2	Outward move command: Jaws move outward
8	Red	GND	0 V DC supply voltage

M8, 8-pin Socket/bracket

The inputs of the product are configured for 24 V DC PNP outputs of the control system.

10.3 Static charge

CAUTION



Non-compliance may result in material damage.

Grounding the product is recommended if ESD sensitive parts come into contact with the product.
Grounding is also recommended in applications that require high EMC shielding.

10.4 Heat dissipation

In the event of high ambient temperatures, the product must be installed on heat-dissipating materials.

If the product is operated under very high ambient temperatures and with fast clock cycles on an ongoing basis, this might reduce its service life.

INFORMATION



▶ The cycle time must therefore be reduced as the temperature increases.

10.5 Installing accessories

NOTICE



Non-compliance may result in material damage.

- ▶ Before installing an accessory, make sure it is suitable for use with the selected variant.
- ▶ You can find information on our website.
- ▶ Please contact Customer Service if you have any questions.

11 Operation

11.1 Freedrive operation (optional)

For manual soft-switching of the robot, the product is equipped with a Freedrive button . The following work steps must be observed for manually teaching in the robot position:

- ▶ To soft-switch the robot, press the Freedrive button.
- ⇒ The robot can be moved manually.
- ⇒ The robot is moved with the product to the desired position.
- ▶ Release the Freedrive Button again as soon as you have reached the desired position.
- ⇒ The robot and product stop at their position.
 - ▶ Observe the information from the robot manufacturer for teaching in and activating the position of the robot and product in the control system.

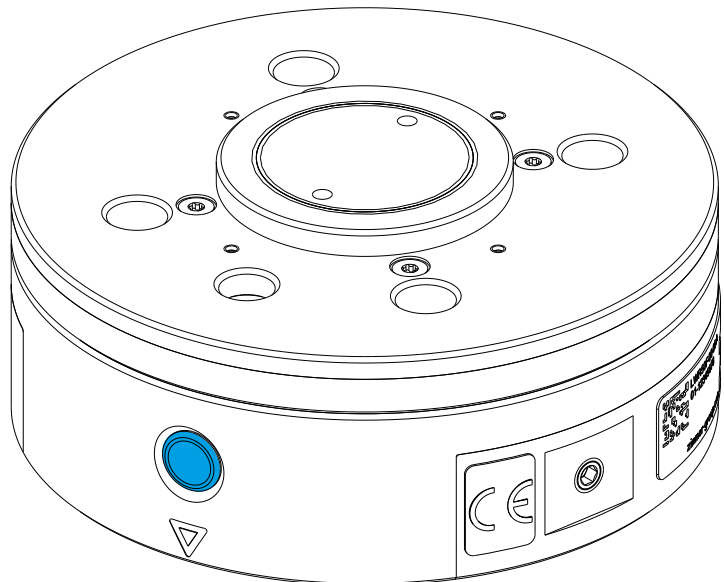

INFORMATION



▶ Details about activation can be found in the information from the robot manufacturer.

12 Maintenance

NOTICE



Material damage resulting from blowing out with compressed air

Blowing out the product with compressed air can cause malfunctions and pose a risk of accidents.

- ▶ Never purge the product with compressed air.

NOTICE



Material damage caused by unsuitable cleaning materials

Liquid and solvent-based cleaning agents can cause malfunctions and pose a risk of accidents.

- ▶ Do not clean the product with any cleaning agents that are liquid or contain solvents.

Operation of the product is maintenance-free.

- ▶ Note that the product could become damaged under the following circumstances:
 - Dirty environment
 - Improper use and use that does not comply with the performance data
 - Permissible temperature range not observed
- ▶ Even though the product is maintenance-free as mentioned above, perform a regular visual inspection to check for any damage or contamination.
- ▶ Have maintenance work that requires disassembly of the product performed by customer service if possible.
- ⇒ Dismantling and reassembling the product without authorization may result in complications, as special installation equipment is required in some cases. Zimmer GmbH accepts no liability for any resulting malfunctions or damage.

13 Decommissioning/disposal

INFORMATION



When the product reaches the end of its operational phase, it can be completely disassembled and disposed of.

- ▶ Disconnect the product completely from the power supply.
- ▶ Dispose of the components properly according to the material groups.
- ▶ Comply with the locally applicable environmental and disposal regulations.

14 RoHS declaration

in terms of the EU Regulation 2011/65/EU

Name and address of the manufacturer:

Zimmer GmbH

📍 Im Salmenkopf
77866 Rheinau, Germany
☎ +49 7844 9138 0
✉ info@zimmer-group.com
🌐 www.zimmer-group.com

We hereby declare that the incomplete machine described below

Product designation: MATCH robot module

Type designation: LWR50F

conforms to the requirements of the directive in its design and the version we put on the market.

Michael Hoch	Rheinau, Germany, 2021-04-01
Authorized representative for the compilation of relevant technical documents	(Place and date of issuance)



Martin Zimmer
(Legally binding signature)
Managing Partner

15 REACH declaration

In terms of the EC Regulation 1907/2006

Name and address of the manufacturer:

Zimmer GmbH

📍 Im Salmenkopf
77866 Rheinau, Germany
☎ +49 7844 9138 0
✉ info@zimmer-group.com
🌐 www.zimmer-group.com

REACH stands for **R**egistration, **E**valuation, **A**uthorisation and **R**estriction of **C**hemicals.

A full declaration of REACH can be obtained from the manufacturer due to the duty to notify in accordance with Art. 33 of the REACH regulation ("Duty to communicate information on substances in articles").

Michael Hoch	Rheinau, Germany, 2021-04-01
Authorized representative for the compilation of relevant technical documents	(Place and date of issuance)



Martin Zimmer
(Legally binding signature)
Managing Partner

16 Declaration of Incorporation

In terms of the EU Machinery Directive 2006/42/EC (Annex II 1 B)

Name and address of the manufacturer:

Zimmer GmbH

📍 Im Salmenkopf
77866 Rheinau, Germany
☎ +49 7844 9138 0
✉ info@zimmer-group.com
🌐 www.zimmer-group.com

We hereby declare that the incomplete machine described below

Product designation: MATCH robot module

Type designation: LWR50F

conform to the requirements of the Machinery Directive, 2006/42/EC, Article 2g, Annex VII.b – Annex II.b, in its design and the version we put on the market.

Basic health and safety requirements:

No. 1.1.2, No. 1.1.3, No. 1.5, No. 1.3.2, No. 1.3.4, No. 1.3.7, No. 1.5.3, No. 1.5.4, No. 1.5.8, No. 1.6.4, No. 1.7.1, No. 1.7.4

A full list of applied standards can be obtained from the manufacturer.

We also declare that the specific technical documents were produced in accordance with Annex VII Part B of this Directive. We undertake to provide the market supervisory bodies with electronic versions of special documents for the incomplete machine through our documentation department, should they have reason to request them.

The incomplete machine may only be commissioned if it has been ascertained, if applicable, that the machine or system in which the incomplete machine is to be installed satisfies the requirements of Directive 2006/42/EC on Machinery and an EC Declaration of Conformity has been drawn up in accordance with Annex II 1 A.

Kurt Ross

Authorized representative for the compilation of relevant technical documents

Rheinau, Germany, 2021-04-01

(Place and date of issuance)

Martin Zimmer
(Legally binding signature)
Managing Partner

17 Declaration of Conformity

As defined by the EC Directive 2014/30/EU on electromagnetic compatibility

Name and address of the manufacturer:

Zimmer GmbH

-  Im Salmenkopf
77866 Rheinau, Germany
-  +49 7844 9138 0
-  info@zimmer-group.com
-  www.zimmer-group.com

We hereby declare that the products described below

- Product designation:** MATCH robot module
- Type designation:** LWR50F

conform to the requirements of the Electromagnetic Compatibility Directive 2014/30/EU in its design and the version we put on the market.

The following harmonized standards have been used:

- DIN EN ISO 12100 Safety of machinery - General principles for design - Risk assessment and risk reduction
- DIN EN 61000-6-3 EMC Generic standard, Emission standard for residential, commercial and light-industrial
- DIN EN 61000-6-2 EMC Generic standard, Emission standard for industrial environments
- DIN EN 61000-6-4 EMC Generic standard, Immunity for industrial environments

A full list of applied standards can be obtained from the manufacturer.

Kurt Ross
Authorized representative for the compilation of relevant technical documents

Rheinau, Germany, 2021-04-01
(Place and date of issuance)



Martin Zimmer
(Legally binding signature)
Managing Partner