



INSTALLATION AND OPERATING INSTRUCTIONS

Pneumatic tool changer

WWR

DDOC00227

THE KNOW-HOW FACTORY

Content

1	Supporting documents	4
1.1	Notices and graphics in the installation and operating instructions	4
2	Safety notices	5
3	Proper use	6
4	Personnel qualification	6
4.1	Electricians	6
4.2	Specialists	6
4.3	Instructed personnel.....	6
4.4	Service personnel.....	6
4.5	Additional qualifications	6
5	Product description	7
5.1	Type plate	8
5.2	Product variants and compatibility	8
6	Functional description	9
6.1	Functional safety	10
6.2	Control	10
6.3	Self-locking mechanism	10
7	Technical data	10
7.1	Protection class.....	10
8	Accessories	11
9	Transportation/storage/preservation	11
10	Installation	12
10.1	Installing the stationary part.....	13
10.2	Installing the loose part	13
10.3	Installing the energy supply	14
10.3.1	Pneumatic control	15
10.4	Mounting the magnetic field sensor.....	17
10.4.1	WWR40F, WWR50F, WWR63F installation sizes	17
10.4.2	WWR80F installation size.....	19
10.4.3	WWR100F installation size.....	20
10.4.4	WWR125F installation size.....	21
10.4.5	WWR160F installation size.....	22
10.5	Installing the inductive sensor	23
10.6	Installing the storage station	24
10.7	Installing accessories	24
11	Maintenance.....	25
12	Decommissioning/disposal	25
13	RoHS declaration.....	26
14	Declaration of Incorporation	27

1 Supporting documents

NOTICE



Read through the installation and operating instructions before installing or working with the product.

The installation and operating instructions contain important notes for your personal safety. They must be read and understood by all persons who work with or handle the product during any phase of the product lifetime.



The documents listed below are available for download on our website www.zimmer-group.com.

- Installation and operating instructions
 - Catalogs, drawings, CAD data, performance data
 - Information on accessories
 - Technical data sheets
 - General Terms and Conditions, including warranty information.
- ⇒ Only those documents currently available on the website are valid.

In these installation and operating instructions, "product" refers to the product designation on the title page!

1.1 Notices and graphics in the installation and operating instructions

DANGER



This notice warns of an imminent danger to the life and health of people. Ignoring these notices can lead to serious injury or even death.

- ▶ You absolutely must comply with the described measures for avoiding these dangers!
- ⇒ The warning symbols are assigned according to the type of danger.

WARNING



This notice warns of a situation that is potentially hazardous to personal health. Ignoring these notices can cause serious injury or damage to health.

- ▶ You absolutely must comply with the described measures for avoiding these dangers!
- ⇒ The warning symbols are assigned according to the type of danger.

CAUTION



This notice warns of a situation that is potentially hazardous to persons. Ignoring these notices can cause minor, reversible injuries.

- ▶ You absolutely must comply with the described measures for avoiding these dangers!
- ⇒ The warning symbols are assigned according to the type of danger.

NOTICE



This notice warns of possible material and environmental damage. Ignoring these notices can result in damage to the product or the environment.

- ▶ You absolutely must comply with the described measures for avoiding these dangers!
- ⇒ The warning symbols are assigned according to the type of danger.

INFORMATION



This category contains useful tips for handling the product efficiently. Failure to observe these tips will not result in damage to the product. This information does not include any information relevant to health or workplace safety.

2 Safety notices

CAUTION



Risk of injury and material damage in case of non-compliance

Installation, commissioning, maintenance and repairs may only be performed by qualified specialists in accordance with these installation and operating instructions.

The product is state-of-the-art.

It is mounted to industrial machines and is used to hold tools.

The following are examples of situations in which the product may cause a hazard:

- The product is not properly installed, used or maintained.
- The product is not used for its designated purpose.
- The locally applicable regulations, laws, directives or guidelines are not observed.
- ▶ The product may only be used in accordance with these installation and operating instructions and the product's technical data. Any changes or additions to the intended use of the product, as well as modifications to the product, such as those in the following examples, require the written permission of the manufacturer:
 - Use of the product under extreme conditions, such as aggressive fluids or abrasive dusts
 - Additional drilled holes or threads
- ⇒ Zimmer GmbH shall accept no liability for any damage caused by improper use. The operator bears sole responsibility.
- ▶ Make sure that the power supply is disconnected before you mount, adjust, modify, maintain or repair the product.
- ▶ Whenever work is carried out on the product, make sure that the product cannot be actuated by mistake.
- ▶ Perform maintenance tasks, renovation work or attachment work outside of the machine's danger zone when possible.
- ▶ Do not reach into the operational range of the product.
- ▶ Observe the specified maintenance intervals and specifications regarding the quality of the operating material.
- ▶ When using the product under extreme conditions, adjust the maintenance interval according to the degree of contamination.

3 Proper use

NOTICE



Material damage and malfunction in case of non-compliance

The product is only to be used in its original state with its original accessories, with no unauthorized changes and within the stipulated parameter limits and operating conditions.

Any other or secondary use is deemed improper.

- ▶ Operate the product only in compliance with the associated installation and operating instructions.
- ▶ Operate the product only when it is in a technical condition that corresponds to the guaranteed parameters and operating conditions.
- ⇒ Zimmer GmbH shall accept no liability for any damage caused by improper use. The operator bears sole responsibility.

- The product is designed exclusively for pneumatic operation.
- The product is intended for industrial use.
- The product is designated for use in closed facilities.
- Direct contact with perishable goods/food is not permitted.
- Observance of the technical data and of the installation and operating instructions are part of proper use.

4 Personnel qualification

WARNING



Injuries and material damage due to inadequate qualification

If inadequately qualified personnel perform work on the product, this can cause serious injuries and significant material damage.

- ▶ All work on the product must be performed by qualified personnel.
- ▶ Before working with the product, read the document in its entirety and make sure that you have understood everything.
- ▶ Observe country-specific accident prevention regulations and the general safety notices.

The following qualifications are a prerequisite for performing various work on the product.

4.1 Electricians

Electricians are able to perform work on electrical systems, can recognize and avoid possible dangers and know the relevant standards and provisions due to their technical training, knowledge and experience.

4.2 Specialists

Specialists are able to perform the assigned work, can recognize and avoid possible dangers and know the relevant standards and provisions due to their technical training, knowledge and experience.

4.3 Instructed personnel

Instructed personnel have been trained by the operating company on the tasks and possible dangers of improper behavior.

4.4 Service personnel

Service personnel are able to perform the assigned work and can recognize and avoid possible dangers due to their technical training, knowledge and experience.

4.5 Additional qualifications

Persons who work with the product must be familiar with the valid safety regulations and laws as well as the standards, guidelines and laws listed in this document.

Personnel who work with the product must have facility-issued authorization to commission, program, configure, operate, maintain and also decommission this product.

5 Product description

The product is a pneumatically operated exchange system.

It consists of a loose part and a stationary part. A storage station is available as an option.

The basic and proven safety principles from EN ISO 13849-1 can be complied with only if original parts from Zimmer GmbH are used.

The original parts from Zimmer GmbH required for the safety principles are:

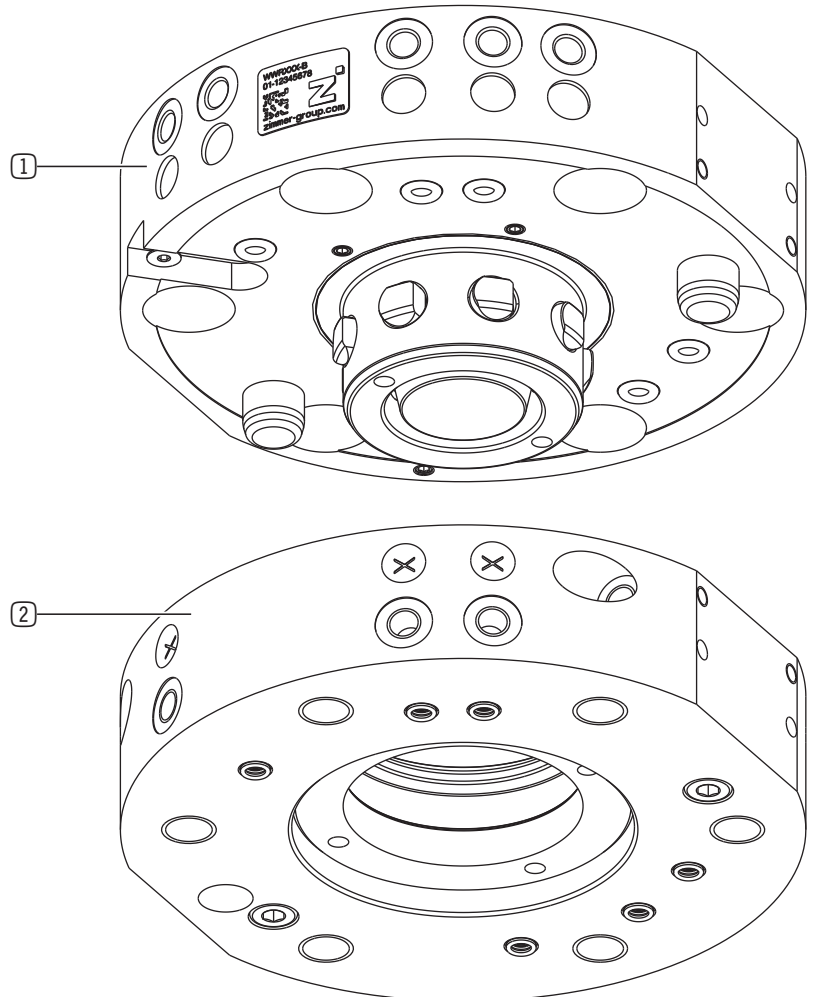

① Stationary part (WWRxxF-B)

② Loose part (WWRxxL-B)

5.1 Type plate

A type plate is attached to the housing of the product.

The article number and the confirmation number are shown on the type plate.

- ① Article number
- ② Confirmation number

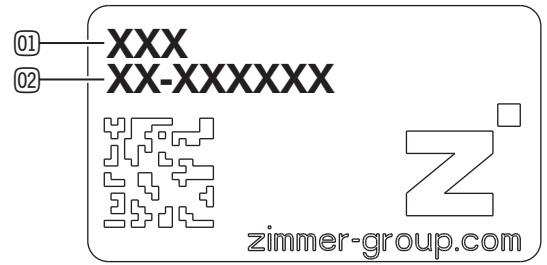

5.2 Product variants and compatibility

INFORMATION



Depending on the installation size of the product, several transmission elements are available for the actuator power supply.

Optionally, the media transmission can be set up with transmission elements at corresponding interfaces on the tool changer.

► Please contact Customer Service if you have any questions.

6 Functional description

INFORMATION



- The product is designed exclusively for pneumatic operation.
- ▶ Always operate the product with an operating pressure between 4 and 10 bar.

The stationary part is installed on a robot system. It is used to hold a loose part.

Several storage stations can be used to hold differently equipped loose parts for operation with a stationary part.

The locking bolts in the locking sleeve enable a friction-locked connection of the stationary and loose part.

The stroke is generated by a double-acting pneumatic rotor cylinder. An integrated spring acts as an energy store and preserves the capability of product locking in the event of a power failure.

The stationary part can be operated with as many loose parts as desired.

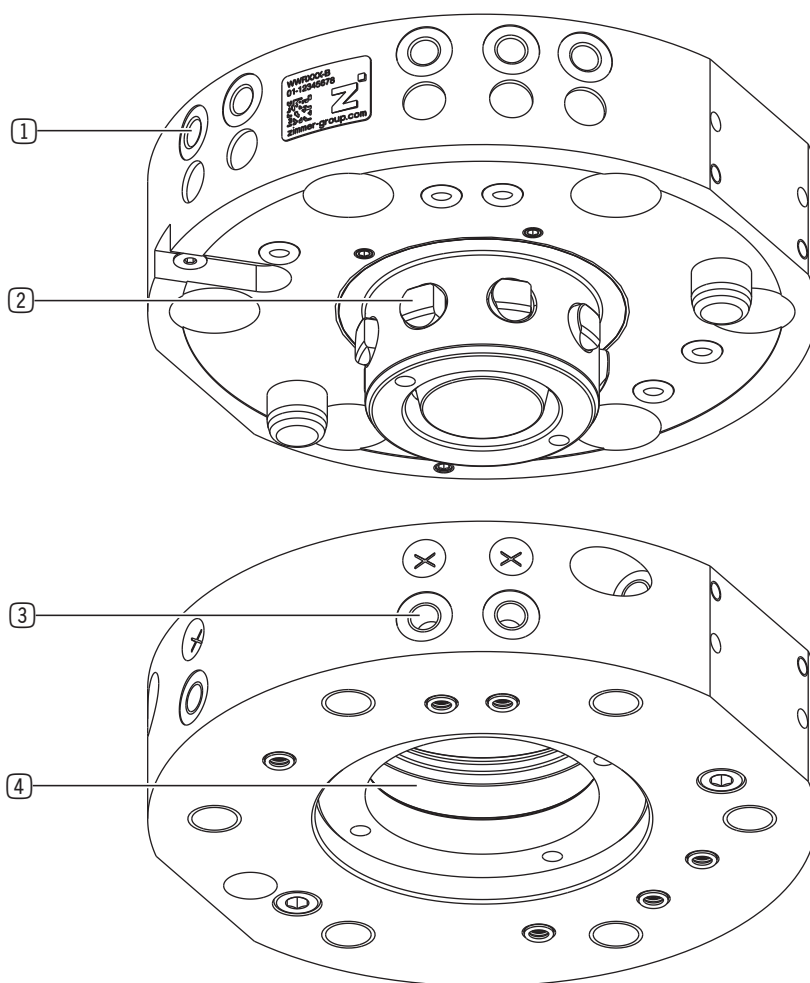

- ① Pneumatic connection
- ② Locking bolt
- ③ Integrated pneumatic feed-through
- ④ Locking sleeve

6.1 Functional safety

For the overall safety of the function, both components (stationary part and loose part) must be taken into account. The safety function that ensures secure locking between the stationary and loose part of the product is implemented via two redundant action channels. They consist of a pneumatic locking and a mechanical safeguard via a spring.

6.2 Control

INFORMATION



- ▶ You can find the information in the technical data sheet on our website.
- ▶ Please contact Customer Service if you have any questions.

6.3 Self-locking mechanism

INFORMATION



- The safety of product locking in the event of a loss of pressure or voltage is ensured by an integrated spring.
- ▶ Please contact Customer Service if you have any questions.

7 Technical data

INFORMATION



- ▶ You can find the information in the technical data sheet on our website.
- This data varies within the series, depending on the specific design.
- ▶ Please contact Customer Service if you have any questions.

7.1 Protection class

NOTICE



In accordance with IEC 60529, the product in the coupled state meets the IP54 degree of protection.

8 Accessories

INFORMATION



If any accessories not sold or authorized by Zimmer GmbH are used, the function of the product cannot be guaranteed. Zimmer GmbH accessories are specifically tailored to the individual products.

- ▶ For optional accessories and those included in the scope of delivery, refer to our website.

9 Transportation/storage/preservation

- ▶ Transport and storage of the product must be done only with the original packaging.
- ▶ If the product has already been installed on the superordinate machine unit, care must be taken during transport to ensure that no unexpected movements can occur.
 - ▶ Before commissioning the product and after transport, check all power and communication connections as well as all mechanical connections.
- ▶ If the product is stored for an extended period, the following points are to be observed:
 - ▶ Keep the storage location as dust-free and dry as possible.
 - ▶ Avoid temperature fluctuations.
 - ▶ Avoid wind/drafts/water condensation formation.
 - ▶ Pack the product and do not expose it to direct sunlight during storage.
- ▶ Clean all components. There must be no soiling left on the components.
- ▶ Visually inspect all components.
- ▶ Remove all foreign substances.
- ▶ Properly remove potential corrosion spots.
- ▶ Close off unused connections using pressure-resistant closures.

10 Installation

WARNING



Risk of injury due to uncontrolled movements

Risk of injury in case of unexpected movement of the machine or system into which the product is to be installed.

- ▶ Switch off the energy supply of the machine before any work.
- ▶ Secure the power supply against being switched on unintentionally.
- ▶ Check the machine for any residual energy that may be present.

CAUTION



Risk of injury due to uncontrolled movements

Risk of injury in the event of uncontrolled movement of the product when the power supply is connected.

- ▶ Switch off the power supply to the machine before carrying out any work.
- ▶ Secure the power supply against being switched on unintentionally.
- ▶ Check the machine for any residual energy that may be present.

NOTICE



▶ Please note that when using hose-free connections, the O-rings must be inserted into the customer-made pockets of the holes on the mounting surface.

- ▶ Note the specified screw lengths.

INFORMATION



Further installation information:

- The mounting screws are not included in the scope of delivery.

Assembly requirements

Permissible unevenness [mm]	Mounting surface length [mm] < 100	< 0.02
	Mounting surface length [mm] > 100	< 0.05
Strength class of the mounting screws (EN ISO 4762)	≥ 8.8	

- ▶ You can find the exact installation positions in the technical data sheet on our website.
- ▶ Install the product on an appropriate mounting surface in accordance with the flatness specifications.
- ▶ Make sure that the mounting surface of the product and connection structure are clean.
- ▶ Comply with the tightening torques of the mounting screws.
- ▶ Verify the permitted load capacity of the required screw connections in accordance with VDI 2230.

10.1 Installing the stationary part

INFORMATION



- ▶ Note the screw-in depth.
 - Screw-in depth $\geq 1.5 \times$ diameter.

- ▶ Insert the straight pin into the designated fit on the stationary part.
- ▶ Insert the stationary part into the robot arm by the connection.
- ▶ Position the stationary part on the robot.
- ▶ Loosely attach the mounting screws.
- ▶ Tighten the mounting screws crosswise.

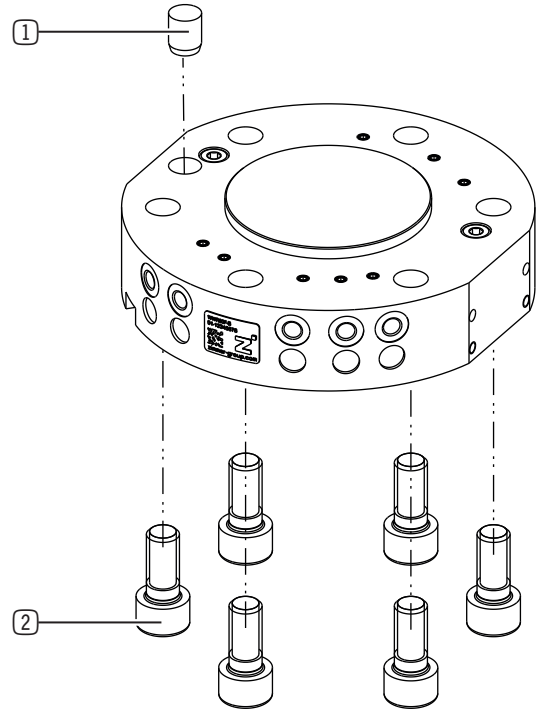

- ① Straight pin (not included in the scope of delivery)
- ② Mounting screw (not included in the scope of delivery)

10.2 Installing the loose part

- ▶ Insert the straight pin into the designated fit on the loose part.
- ▶ Position the loose part on the tool.

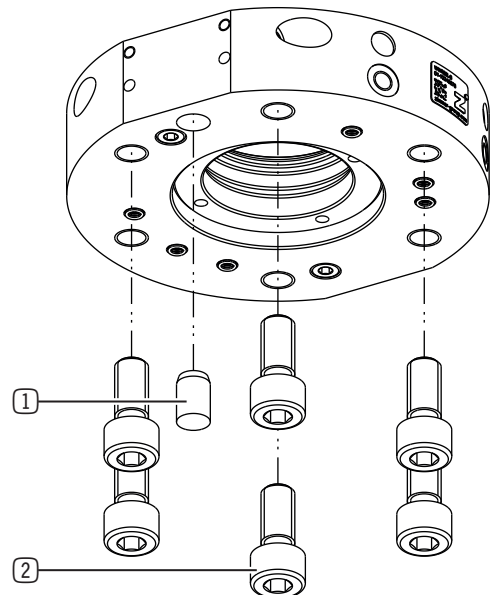

- ① Straight pin (not included in the scope of delivery)
- ② Mounting screw (not included in the scope of delivery)

10.3 Installing the energy supply

NOTICE



- ▶ You can find information on available pneumatic connections on our website.
- ▶ Close off unused connections using pressure-resistant closures.
- ▶ The authorized connections that are available can be found in the accessories list on our website. The necessary ordering information can also be found there.
- ▶ Use compressed air in accordance with DIN ISO 8573-1 [7:4:4].

- ▶ Mount the push-fit fitting.
 - ▶ Use the marked connections A and B for this purpose.

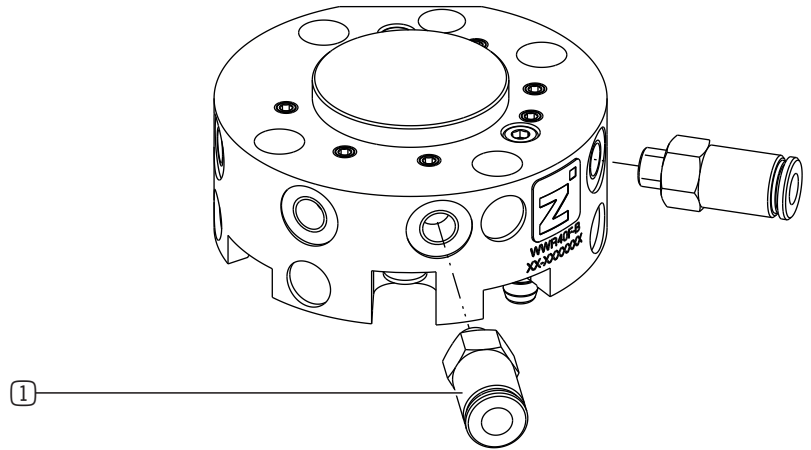

① Push-fit fitting

10.3.1 Pneumatic control

INFORMATION



- ▶ Please note that the connection to the A marking is used for product locking.
- ▶ Please note that the connection to the B marking is used for product unlocking.

The following examples show two control categories. In accordance with EN ISO 13849-1, the product can be controlled so that the required performance level is achieved.

INFORMATION



- The product can be actuated and operated using any control architecture in accordance with EN ISO 13849-1. The deciding factor here is which performance level PL_r should be achieved.
- ▶ Please note the $MTTF_d$ values of the safety-related parts of the control system (SRP/CS) being used as well as the degree of diagnostic coverage (DC) achieved.

INFORMATION



- The secure holding of coupled tools must be taken into account as this is a relevant safety function for the product.
- Risk prevention can be achieved through the use of various protection measures, both via SRP/CS measures as well as via non-SRP/CS measures. The goal of the protection measures is to reach a safe status.
- Measures for fault prevention suffice for applications with a risk of PL_{ra} to PL_{rc} .
- For applications with a risk higher than PL_{rd} to PL_{re} , the structure of the SRP/CS can provide the measures to avoid, note or tolerate the faults.
- Suitable measures include redundancy, diversity and monitoring in accordance with EN ISO 12100-2:2003, Section 3 and EN IEC 60204-1:2000.

10.3.1.1 Control category 1 example

Single-channel

The mechanical component (spring) is supported by the pneumatic component (pressure).

Both components alone cannot maintain the safety function.

- Proven components
- 0 Fault detection
- Activation via a 5/2-way valve

⇒ PL_c is achieved.

In order to achieve the safety function, the use of proven components in accordance with EN ISO 13849-1, Chapter 6.2.4 are sufficient.

- Magnetic field sensors S3 and S4 are available for the final position check.

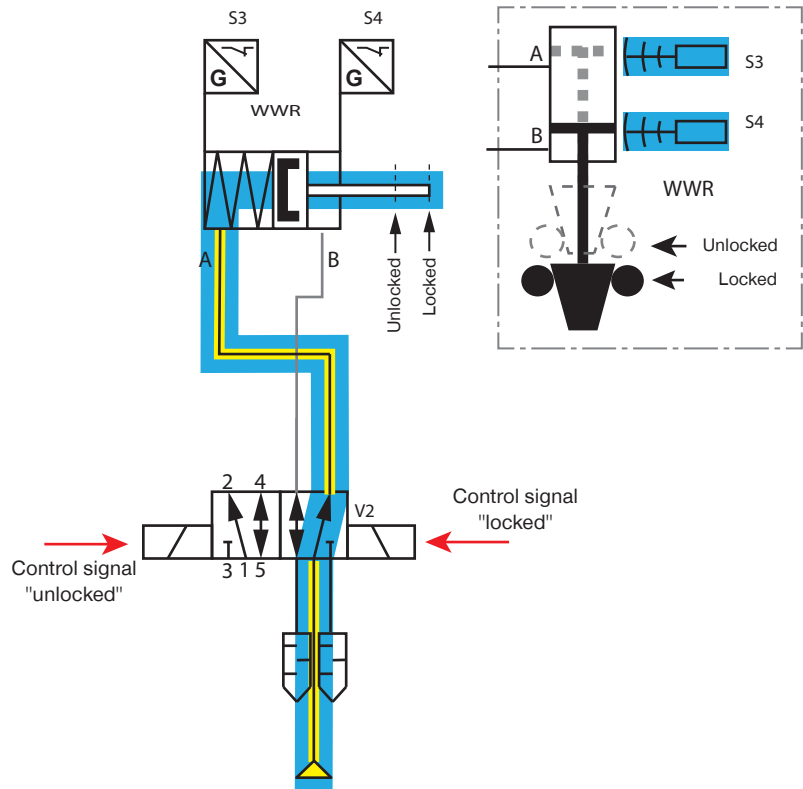

10.3.1.2 Control category 3 example

NOTICE



- ▶ Please note that the maximum handling weight, the associated lever arms and the acceleration values may not be exceeded for the implementation of control category 3.
- ▶ Refer to the technical data sheet on our website for the values for the maximum handling weight.

Dual-channel

- The mechanical component (spring) operates as action channel 1 (yellow marking).
 - The pneumatic component (pressure) operates as action channel 2 (blue marking).
- ⇒ Each of the individual components alone can maintain the safety function.

There is fault elimination in accordance with EN ISO 13849-2, Annex A, Table A.5 for the mechanical action channel.

There is a B10d value of 5 million cycles for the pneumatic action channel.

- The degree of diagnostic coverage is $60\% \leq DC < 90\%$.
- Two mono-stable valves are used.
 - ⇒ The safety functions "reversing" and/or "unexpected startup" (unlock) are realized.
 - ⇒ PL_d to 100% can be achieved.
- Optional magnetic field sensors (S3 and S4) or a 2-point magnetic field sensor are available for the final position check.
- An optional pressure sensor can be used for pressure monitoring.
 - ⇒ This can increase the degree of diagnostic coverage to $90\% \leq DC < 99\%$.
- Optional sensors are available for storage station monitoring.
- Optional energy elements are available for tool coding.
- Optional sensors are available for "loose part present" sensing.

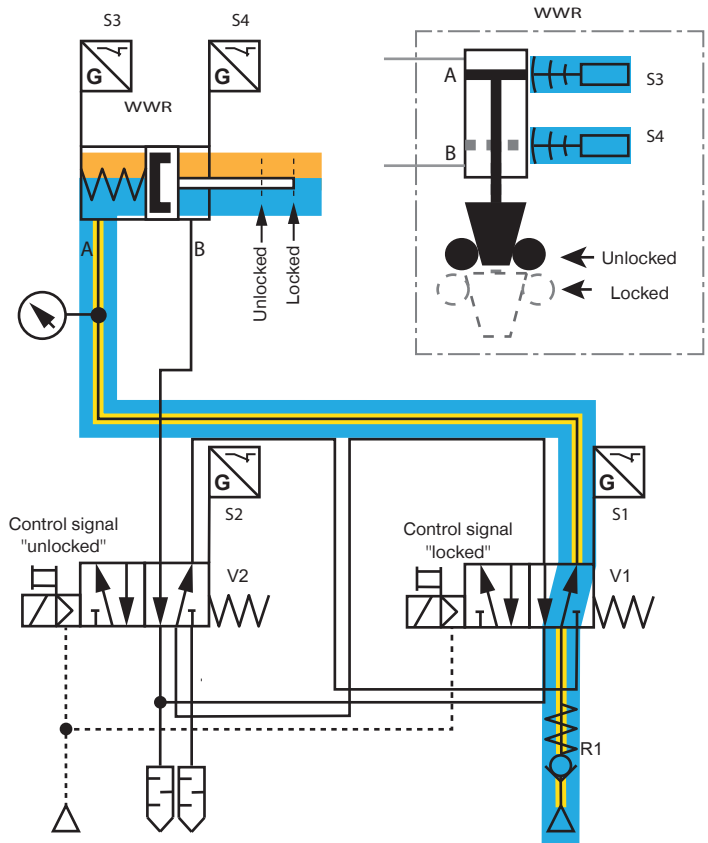

10.4 Mounting the magnetic field sensor

Various sensors are available for sensing the piston position depending on the installation size. These sensors provide information on the respective position of the piston and increase safety when operating the product.

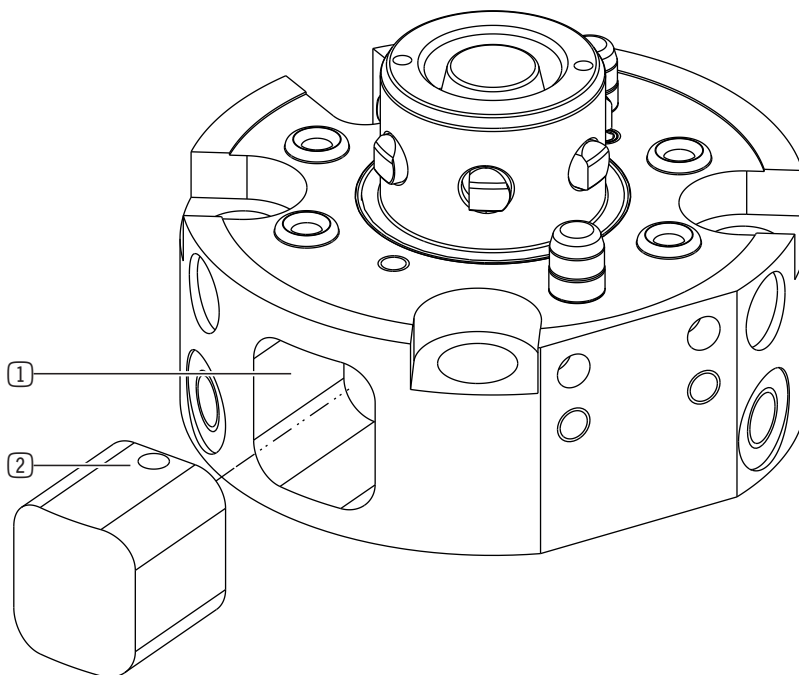

- ① Opening on the stationary part
- ② Sealing

10.4.1 WWR40F, WWR50F, WWR63F installation sizes

Design size	1-point magnetic field sensor
WWR40F	ZUB0015
WWR50F	ZUB0016
WWR63F	ZUB0017

Design size	2-point magnetic field sensor
WWR40F	ZUB088929
WWR50F	ZUB088928
WWR63F	ZUB088927

As an example, the figures show the installation of sensors ZUB0015 and ZUB088929.

- ▶ Remove the seal.
- ▶ Slide the sensors into the sensor bracket.
- ▶ Securely clamp the sensors with the grub screw.
- ▶ Insert the sensor bracket into the opening on the stationary part.
- ▶ Securely clamp the sensor bracket using the grub screw.

ZUB0015

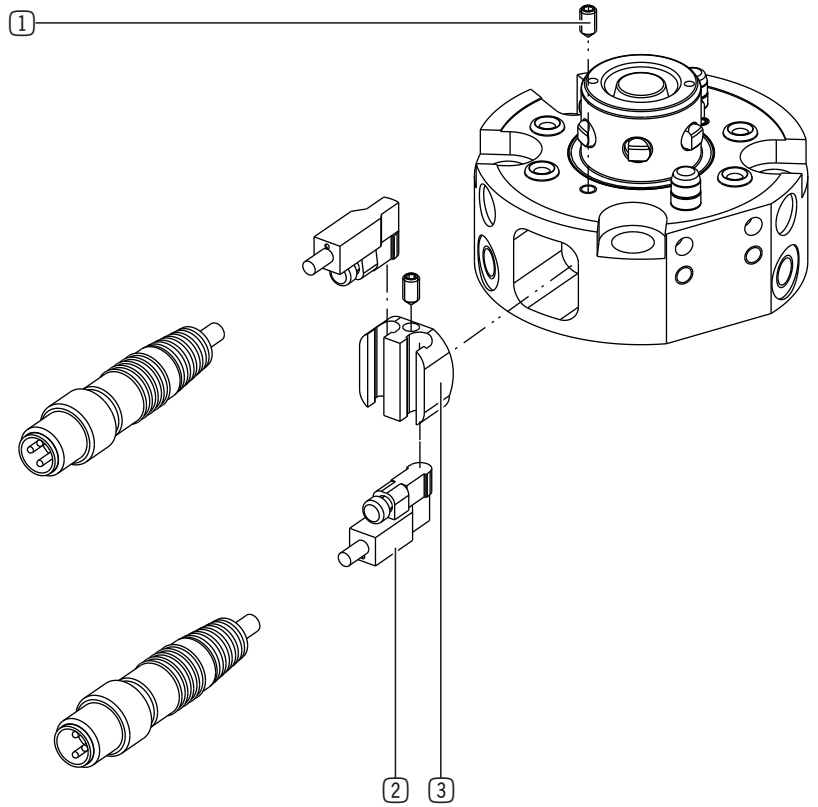

ZUB088929

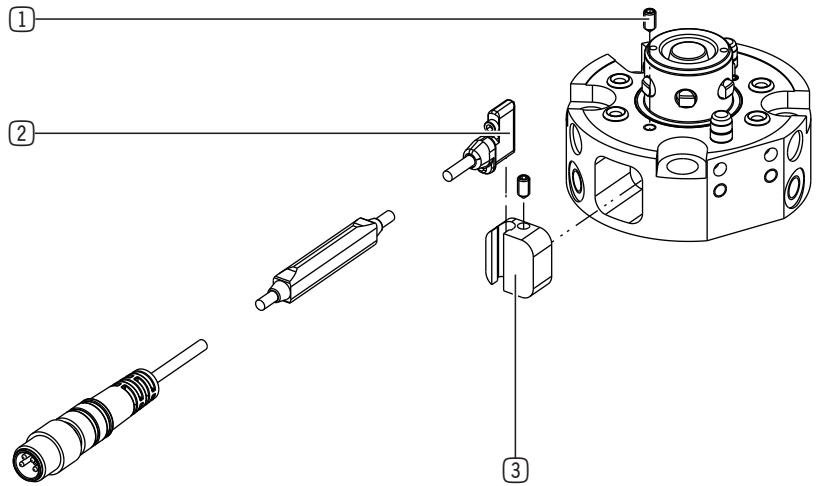

- ① Grub screw
- ② Sensor
- ③ Sensor bracket

10.4.2 WWR80F installation size

Design size	1-point magnetic field sensor
WWR80F	ZUB0018
Design size	2-point magnetic field sensor
WWR80F	ZUB088925

As an example, the figures show the installation of a 1-point and 2-point magnetic field sensor.

- ▶ Remove the seal.
- ▶ Slide the sensors into the sensor bracket.
- ▶ Securely clamp the sensors with the grub screw.
- ▶ Position the spacer on the sensor bracket with the grub screw and the straight pin.
- ▶ Install the components with the mounting screw.
- ▶ Insert the sensor bracket into the opening on the stationary part up to the end stop.
- ▶ Secure the sensor bracket into position from above with the grub screws.

ZUB0018

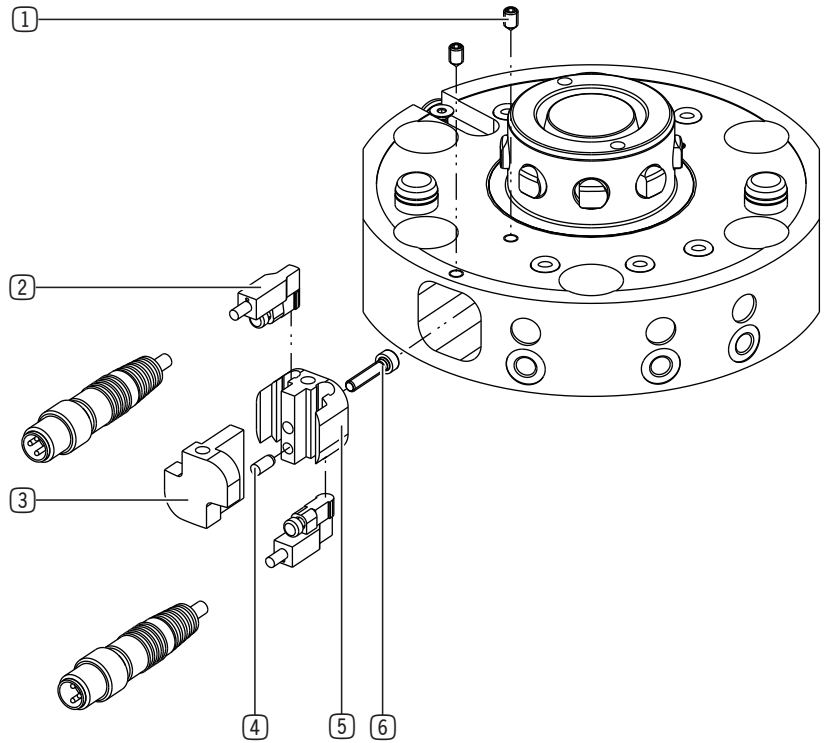

ZUB088925

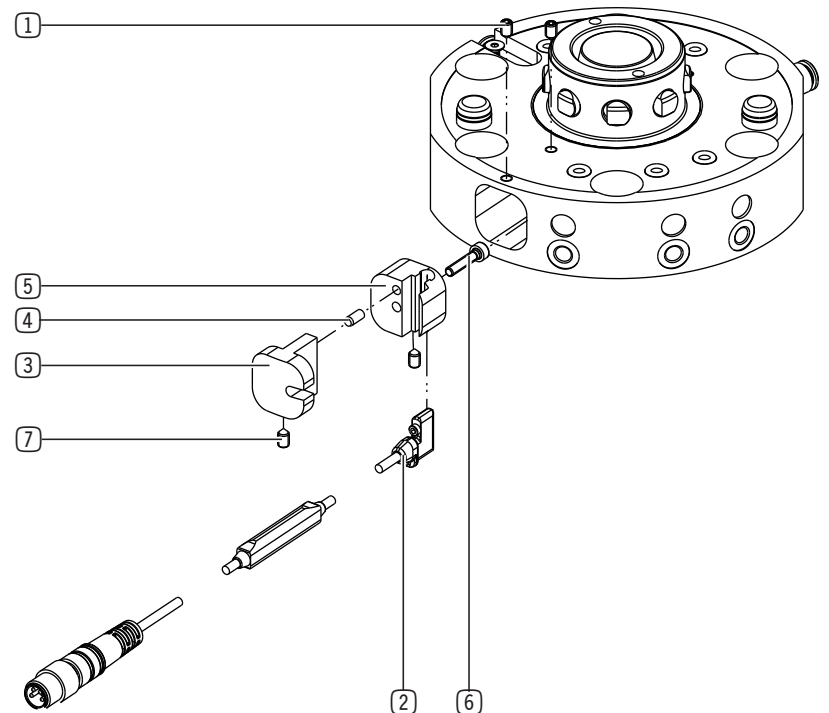

- ① Grub screw
- ② Sensor
- ③ Spacer
- ④ Straight pins
- ⑤ Sensor bracket
- ⑥ Mounting screw
- ⑦ Grub screw

10.4.3 WWR100F installation size

Design size	1-point magnetic field sensor
WWR100F	ZUB0019
Design size	2-point magnetic field sensor
WWR100F	ZUB088924

As an example, the figures show the installation of a 1-point and 2-point magnetic field sensor.

- ▶ Remove the seal.
- ▶ Slide the sensors into the sensor bracket.
- ▶ Position the spacer on the sensor bracket.
- ▶ Slide the sensor bracket into the opening on the stationary part up to the end stop.
 - ▶ Make sure that the marking on the sensor bracket faces downwards.
- ▶ Route the sensor cables through the holes of the cover plate.
- ▶ Install the cover plate to the opening on the stationary part.

ZUB0019

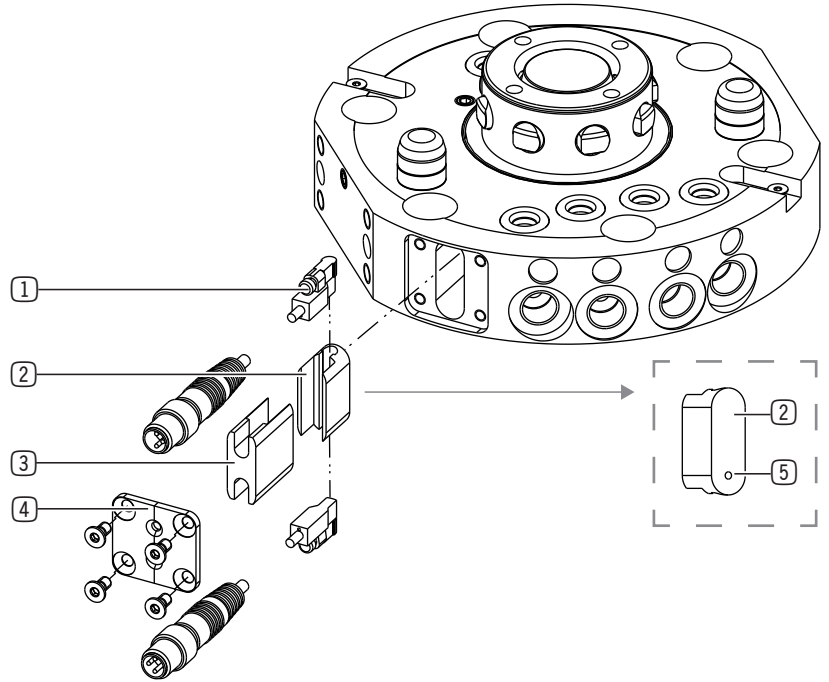

ZUB088924

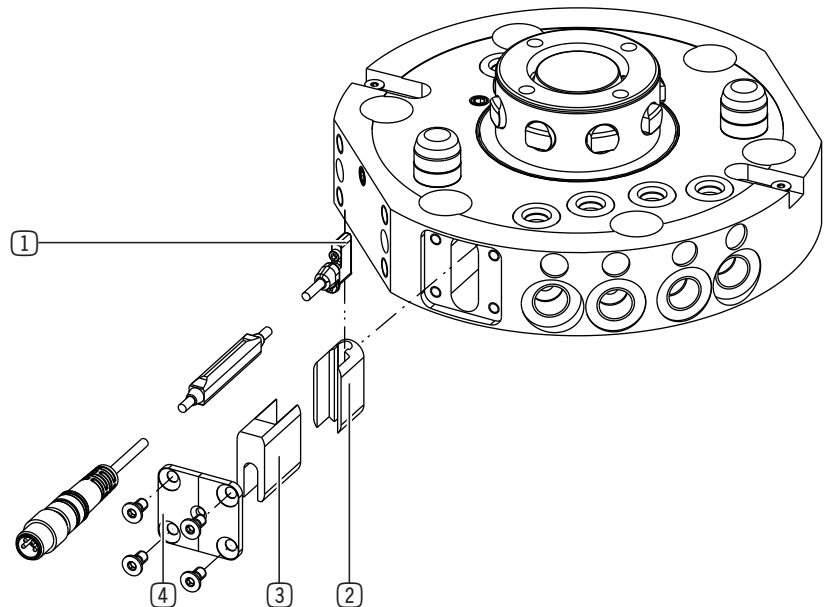

- ① Sensor
- ② Sensor bracket
- ③ Spacer
- ④ Cover plate
- ⑤ Marking

10.4.4 WWR125F installation size

Design size	1-point magnetic field sensor
WWR125F	ZUB0020
Design size	2-point magnetic field sensor
WWR125F	ZUB088923

As an example, the figures show the installation of a 1-point and 2-point magnetic field sensor. **ZUB0020**

- ▶ Remove the seal.
- ▶ Slide the sensors into the sensor bracket.
- ▶ Position the spacer on the sensor bracket.
- ▶ Slide the sensor bracket into the opening on the stationary part up to the end stop.
 - ▶ Make sure that the marking on the sensor bracket faces downwards.
- ▶ Route the sensor cables through the holes of the cover plate.
- ▶ Install the cover plate to the opening on the stationary part.

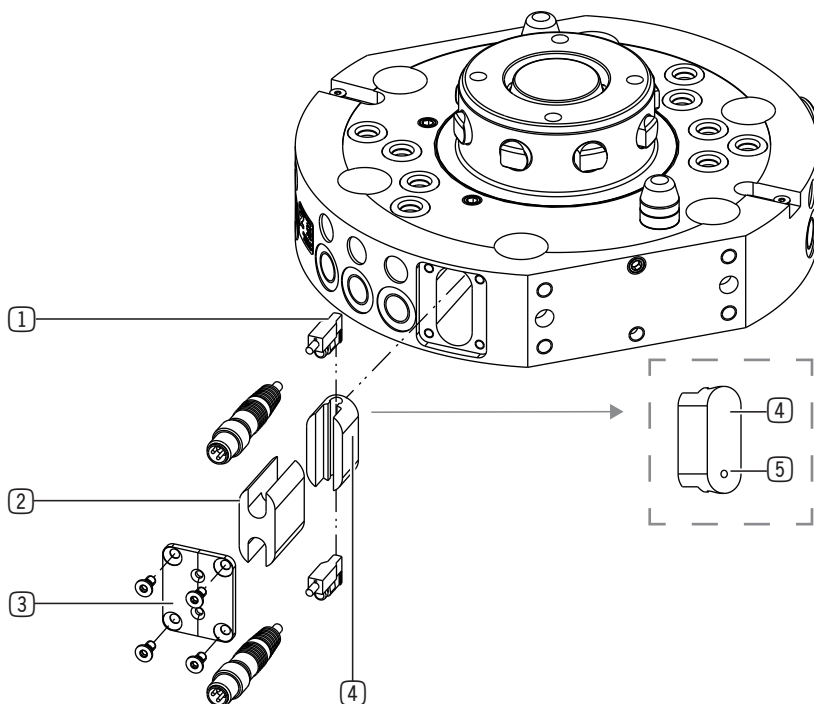

ZUB088923

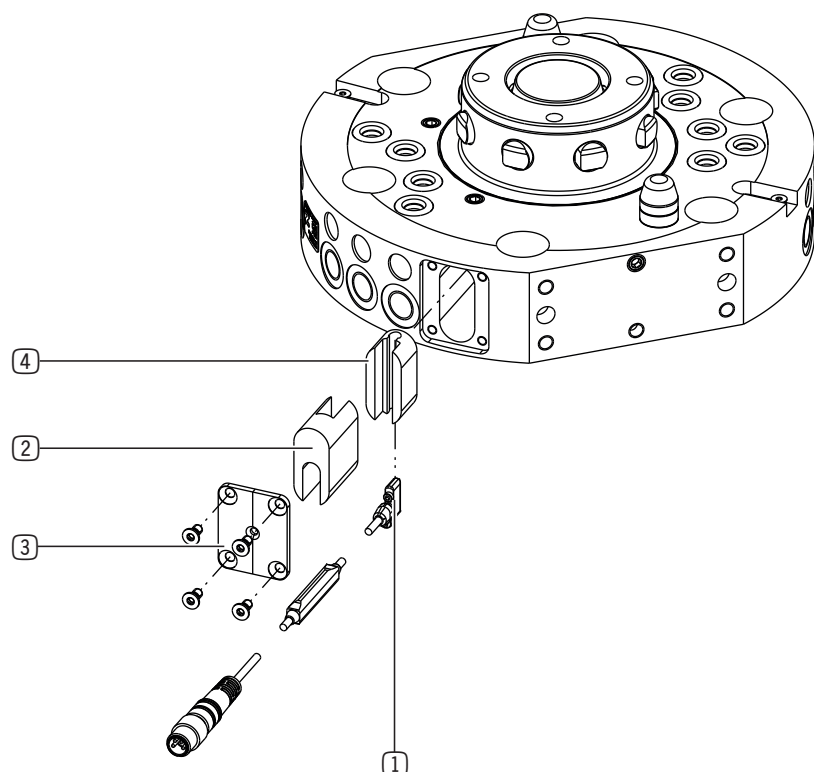

- ① Sensor
- ② Spacer
- ③ Cover plate
- ④ Sensor bracket
- ⑤ Marking

10.4.5 WWR160F installation size

Design size	1-point magnetic field sensor
WWR160F	ZUB0021
Design size	2-point magnetic field sensor
WWR160F	ZUB088922

As an example, the figures show the installation of a 1-point and 2-point magnetic field sensor.

- ▶ Remove the seal.
- ▶ Slide the sensors into the sensor bracket.
- ▶ Position the spacer on the sensor bracket.
- ▶ Slide the sensor bracket into the opening on the stationary part up to the end stop.
 - ▶ Make sure that the marking on the sensor bracket faces downwards.
- ▶ Route the sensor cables through the holes of the cover plate.
- ▶ Install the cover plate to the opening on the stationary part.

ZUB0021

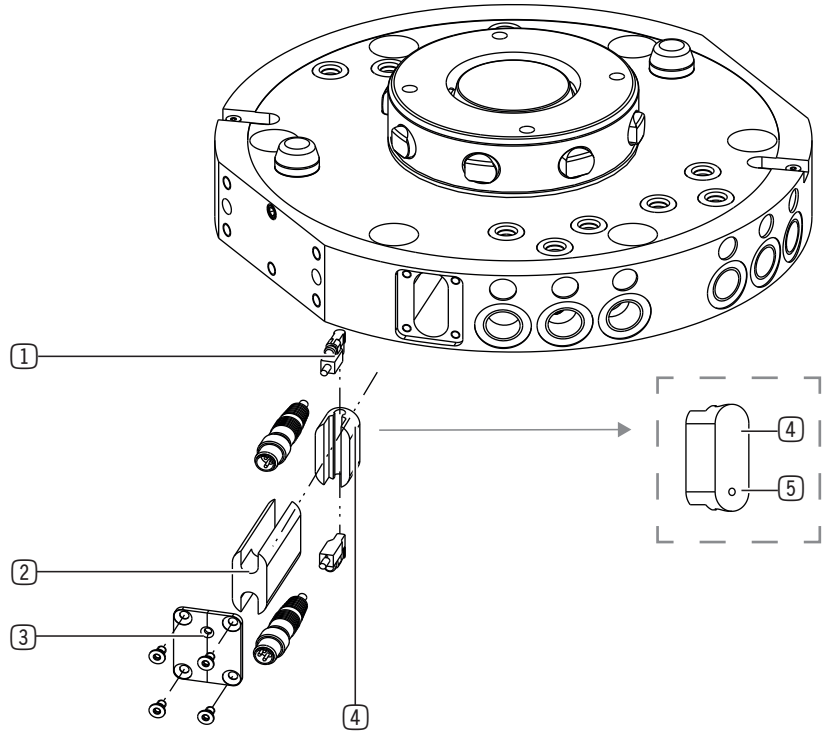

ZUB088922

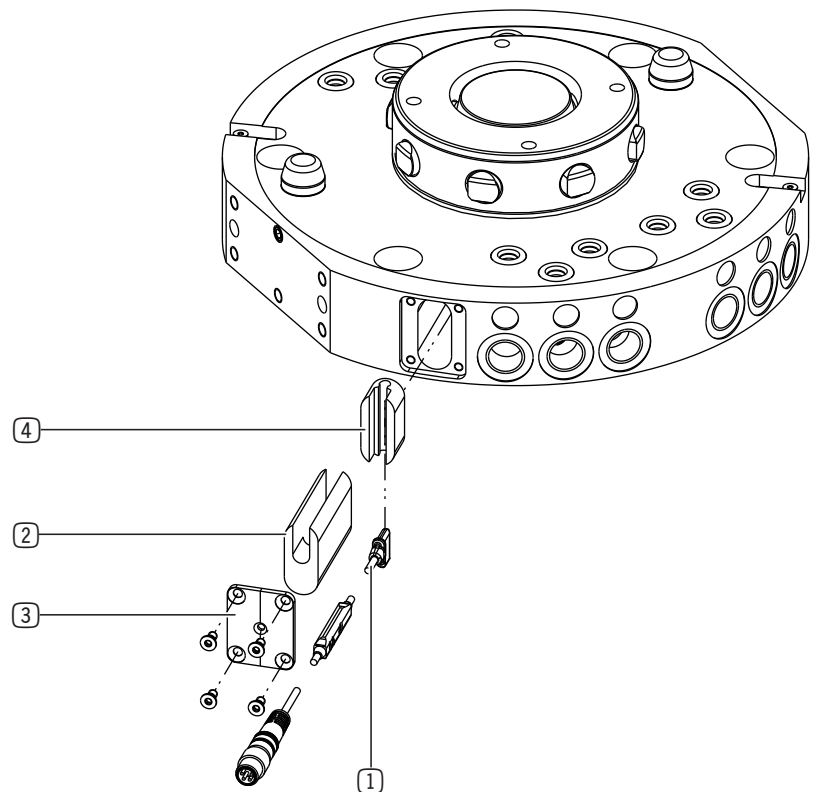

- ① Sensor
- ② Spacer
- ③ Cover plate
- ④ Sensor bracket
- ⑤ Marking

10.5 Installing the inductive sensor

INFORMATION



The inductive sensor is used for product safety and can be used to detect the "loose part present" signal.

WWR40 installation size

- ▶ Position the mounting piece in the corresponding fit on the stationary part.
- ▶ Install the mounting piece on the stationary part with the mounting screw.
- ▶ Install the sensor on the mounting piece with the mounting screw.

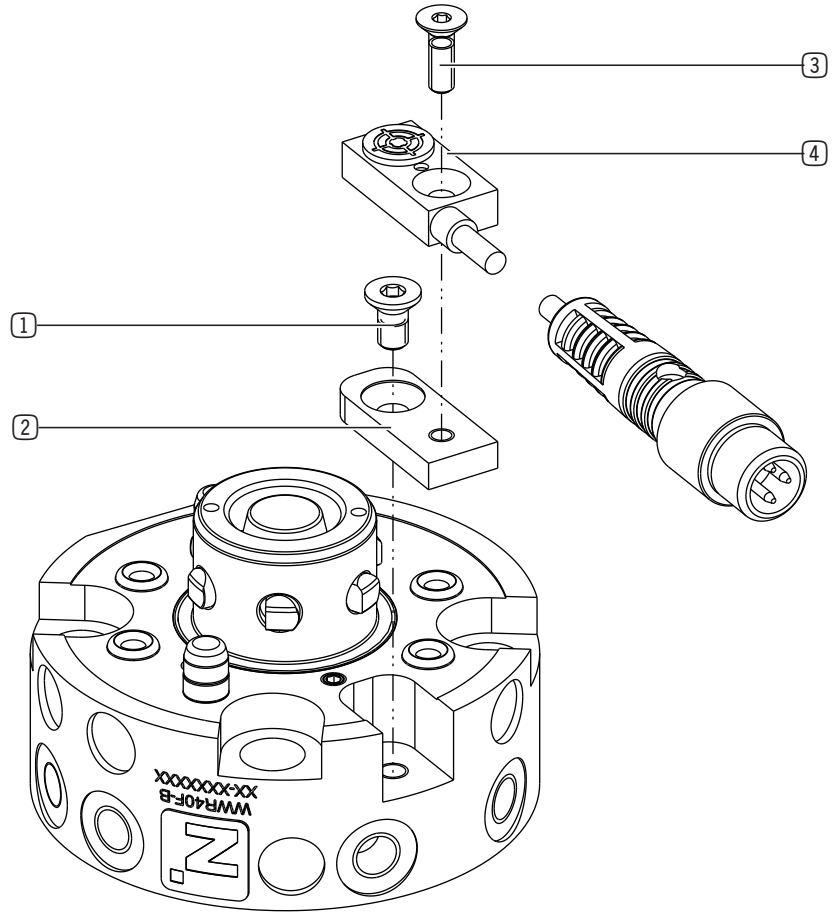

- ① Mounting piece mounting screw
- ② Mounting piece
- ③ Sensor mounting screw
- ④ Sensor

Other installation sizes

- ▶ Position the sensor in the corresponding fit on the stationary part.
- ▶ Install the sensor on the fit with the mounting screw.

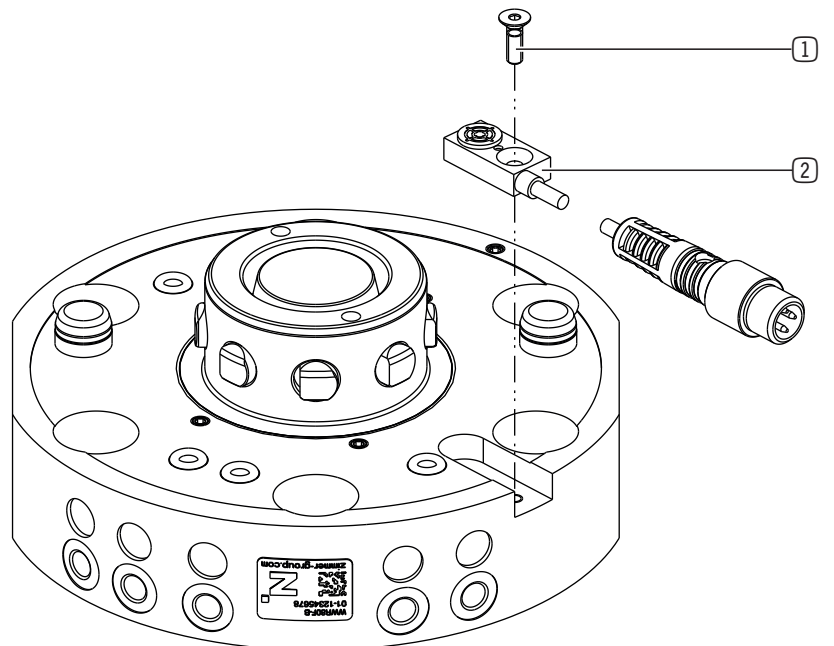

- ① Mounting screw
- ② Sensor

10.6 Installing the storage station

The storage station is a device in which a completely equipped loose part can be held ready in a defined position.

- ▶ Mount the storage station on the support structure.
- ▶ Remove the pins from the storage station.
- ▶ Mount the pins on the loose part.
- ▶ Slide the loose part along the guide rails in the storage station.
- ▶ Make sure that the loose part is engaged in the retaining clamps.

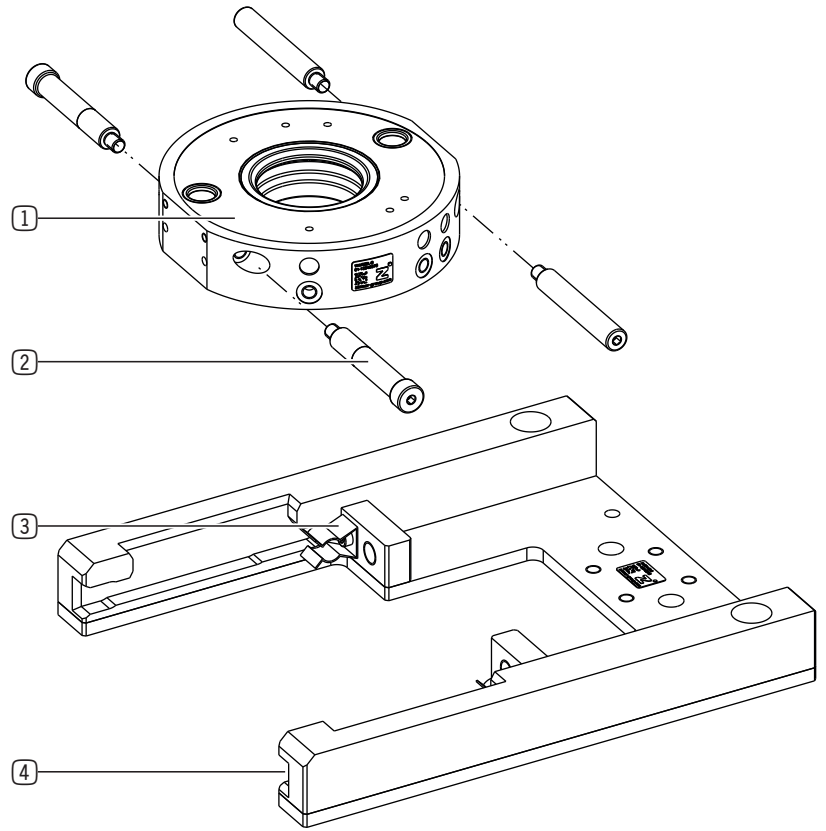

- ① Loose part
- ② Pin
- ③ Retaining clamp
- ④ Guide rail

10.7 Installing accessories

NOTICE



- ▶ Before installing an accessory, make sure it is suitable for use with the selected variant.
- ▶ You can find information on our website.
- ▶ Please contact Customer Service if you have any questions.

11 Maintenance

NOTICE

**Material damage resulting from blowing out with compressed air**

Blowing out the product with compressed air can cause malfunctions and pose a risk of accidents.

- ▶ Never purge the product with compressed air.

NOTICE

**Material damage caused by unsuitable cleaning materials**

Liquid and solvent-based cleaning agents can cause malfunctions and pose a risk of accidents.

- ▶ Do not clean the product with any cleaning agents that are liquid or contain solvents.

Maintenance-free operation of the product is guaranteed for up to **5 million cycles**.

▶ Note that the product could become damaged under the following circumstances:

- Operation with impermissible compressed air
 - Dirty environment
 - Improper use and use that does not comply with the performance data
 - Permissible temperature range not observed
- ▶ Even though the product is maintenance-free as mentioned above, perform a regular visual inspection to check for any damage or contamination.
- ▶ Have maintenance work that requires disassembly of the product performed by customer service if possible.
- ⇒ Dismantling and reassembling the product without authorization may result in complications, as special installation equipment is required in some cases. Zimmer GmbH accepts no liability for any resulting malfunctions or damage.

12 Decommissioning/disposal

INFORMATION



When the product reaches the end of its operational phase, it can be completely disassembled and disposed of.

- ▶ Disconnect the product completely from the power supply.
- ▶ Dispose of the components properly according to the material groups.
- ▶ Comply with the locally applicable environmental and disposal regulations.

13 RoHS declaration

in terms of the EU Regulation 2011/65/EU

Name and address of the manufacturer:

Zimmer GmbH

- 📍 Im Salmenkopf
77866 Rheinau, Germany
- ☎ +49 7844 9138 0
- ✉ info@zimmer-group.com
- 🌐 www.zimmer-group.com

We hereby declare that the incomplete machine described below

- Product designation:** Pneumatic tool changer
- Type designation:** WWR

conforms to the requirements of the directive in its design and the version we put on the market.

Michael Hoch
Authorized representative for the
compilation of relevant technical
documents

Rheinau, Germany, 2020-05-15
(Place and date of issuance)

Martin Zimmer
(Legally binding signature)
Managing Partner

14 Declaration of Incorporation

In terms of the EU Machinery Directive 2006/42/EC (Annex II 1 B)

Name and address of the manufacturer:

Zimmer GmbH

- 📍 Im Salmenkopf
77866 Rheinau, Germany
- ☎ +49 7844 9138 0
- ✉ info@zimmer-group.com
- 🌐 www.zimmer-group.com

We hereby declare that the incomplete machine described below

- Product designation:** Pneumatic tool changer
- Type designation:** WWR

conform to the requirements of the Machinery Directive, 2006/42/EC, Article 2g, Annex VII.b – Annex II.b, in its design and the version we put on the market.

Basic health and safety requirements:

No. 1.1.2, No. 1.1.3, No. 1.1.5, No. 1.3.2, No. 1.3.4, No. 1.3.7, No. 1.3.9, No. 1.5.3, No. 1.5.4, No. 1.6.4, No. 1.7.1, No. 1.7.4

A full list of applied standards can be obtained from the manufacturer.

We also declare that the specific technical documents were produced in accordance with Annex VII Part B of this Directive. We undertake to provide the market supervisory bodies with electronic versions of special documents for the incomplete machine through our documentation department, should they have reason to request them.

The incomplete machine may only be commissioned if it has been ascertained, if applicable, that the machine or system in which the incomplete machine is to be installed satisfies the requirements of Directive 2006/42/EC on Machinery and an EC Declaration of Conformity has been drawn up in accordance with Annex II 1 A.

Kurt Ross

Authorized representative for the compilation of relevant technical documents

Rheinau, Germany, 2020-05-15

(Place and date of issuance)



Martin Zimmer
(Legally binding signature)
Managing Partner