

UPÍNACÍ SYSTÉM NULOVÉHO BODU SPN

SPZ062 – UPÍNACÍ ČAP

► TECHNICKÉ ÚDAJE

Objednávacie č.	► Technické údaje		
	SPZ062BZ08-B	SPZ062BE08-B	SPZ062BS08-B
Ød1 [mm]	12	12	12
Ød2 [mm]	17	16,85	17
Ød3 [mm]	14,3	14,3	14,3
ØD1 [mm]	12	12	12
a [mm]	2,9	2,9	2,9
g [mm]	12	12	12
l [mm]	19,5	19,5	19,5
SW [mm]	12	12	12
T [mm]	3	3	3
M *	M8	M8	M8
Mx **	M6	M6	M6

*ISO 4762

Pridržavacia sila 12.9 max. [kN]: M6 = 15 ; M8 = 25 ; M10 = 35 ; M12 = 50 ; M16 = 75

Pridržavacia sila 10.9 max. [kN]: M6 = 12 ; M8 = 20 ; M10 = 30 ; M12 = 40 ; M16 = 60

**ISO 10642

Pridržavacia sila 12.9 max. [kN]: M6 = 12 ; M8 = 20 ; M10 = 28 ; M12 = 40 ; M16 = 60

Pridržavacia sila 10.9 max. [kN]: M6 = 9,5 ; M8 = 16 ; M10 = 24 ; M12 = 32 ; M16 = 48

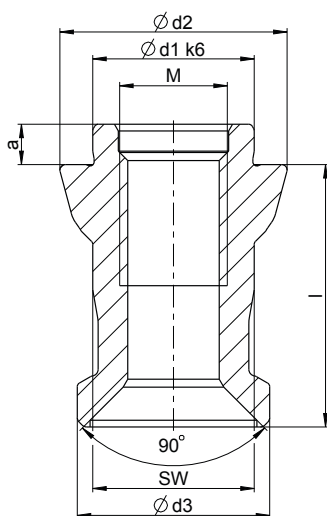
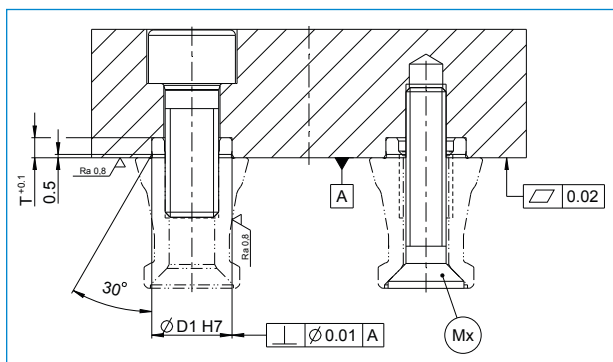

SPZ062BZ08-B
Strediaci čap

SPZ062BE08-B
Vťahovací čap

SPZ062BS08-B
Nožový čap

