

# 2-JAW ANGULAR GRIPPERS

## SERIES GPW5000

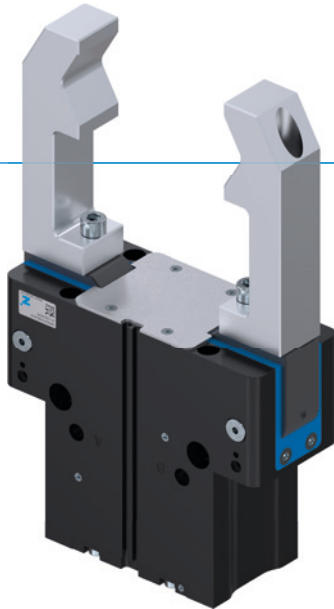







### ▶ PRODUCT ADVANTAGES



#### “The Universal One”

- ▶ **Highest performance with the smallest dimensions**  
Features a one-of-a-kind ratio of net mass to gripper finger length and gripping moment. The performance of your machine is increased as a result.
- ▶ **Versatile applicability**  
Thanks to standard functionality such as IP64 and corrosion protection, you are able to use these grippers in almost any of your applications. Even the toughest environments are no problem.
- ▶ **Robust and process-reliable**  
Thanks to a maintenance-free design up to 30 million cycles and the most solid force transmission possible, process assurance is maximized.

### ▶ SERIES CHARACTERISTICS

Installation size	Base version	Variants	
GPW50XX	NC	-00	-20
 Spring closing C	●	Basic equipment	High Temperature Version
 30 million maintenance-free cycles (max.)	●		
 Inductive sensor	●		
 Magnetic field sensor	●		
 Protected against corrosion	●		
 Purged air	●		
 IP 64	●		
 Temperature-resistant	●		



## ► BENEFITS IN DETAIL

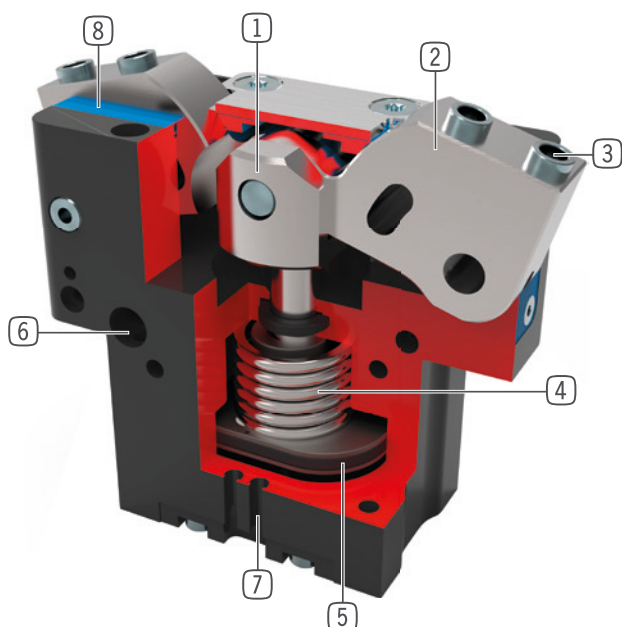

- ① **Positively driven lever mechanism**
  - synchronized the movement of the gripper jaws
- ② **Gripper jaw**
  - Gripper fingers mounted using removable centering sleeves
- ③ **Removable centering sleeves**
  - quick and economical positioning of the gripper fingers
- ④ **Integrated gripping force safety device**
  - Spring built into cylinder chamber as an energy store
- ⑤ **Drive**
  - Double-acting pneumatic rotor cylinder
- ⑥ **Mounting and positioning**
  - Alternatively, on several sides for customized mounting
- ⑦ **Sensing slot**
  - mounting and positioning of magnetic field sensors
- ⑧ **Dual lip seal**
  - IP64
  - Prevents grease from being squeezed out, increasing service life

## ► TECHNICAL DATA

Installation size	Stroke per jaw (+/-)	Gripping force	Weight	IP class
	[°]	[N]	[kg]	
GPW5008	+15/-2	1450	0.92	IP64
GPW5013	+15/-2	4200	3	IP64
GPW5025	+15/-2	14500	12	IP64

## ► FURTHER INFORMATION IS AVAILABLE ONLINE



All information just a click away at: [www.zimmer-group.com](http://www.zimmer-group.com). Find data, illustrations, 3D models and operating instructions for your installation size using the order number for your desired product. Quick, clear and always up-to-date.

# 2-JAW ANGULAR GRIPPERS

## INSTALLATION SIZE GPW5013

### ▶ PRODUCT SPECIFICATIONS



#### ▶ Gripping force diagram

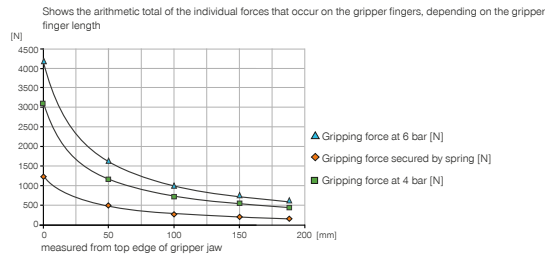

#### ▶ Forces and moments

Displays static forces and moments that can also have an effect, besides the gripping force.

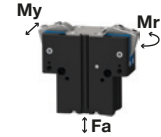

Mr [Nm]	110
My [Nm]	130
Fa [N]	3300

### ▶ TECHNICAL DATA

Order no.	Technical data
	<b>GPW5013NC-00-A</b>
Stroke per jaw (+/-) [°]	+15/-2
Gripping moment in closing max. [Nm]	130
Gripping moment secured by spring min. [Nm]	39.5
Gripping force in closing at 0° [N]*	4200
Closing time [s]	0.08
Opening time [s]	0.12
Dead weight of mounted gripper finger max. [kg]	2.4
Length of the gripper fingers max. [mm]	185
Repetition accuracy +/- [mm]	0.01
Operating pressure min. [bar]	4
Operating pressure max. [bar]	8
Nominal operating pressure [bar]	6
Operating temperature [°C]	-10 ... +90
Air volume per cycle [cm <sup>3</sup> ]	160
Protection to IEC 60529	IP64
Weight [kg]	3

\*measured from top edge of gripper jaw

#### ▶ Technical Data - High Temperature Version

Order no.	Technical data - High Temperature Version
	<b>GPW5013NC-20-A</b>
Operating temperature [°C]	-10 ... +130

## TECHNICAL DRAWINGS

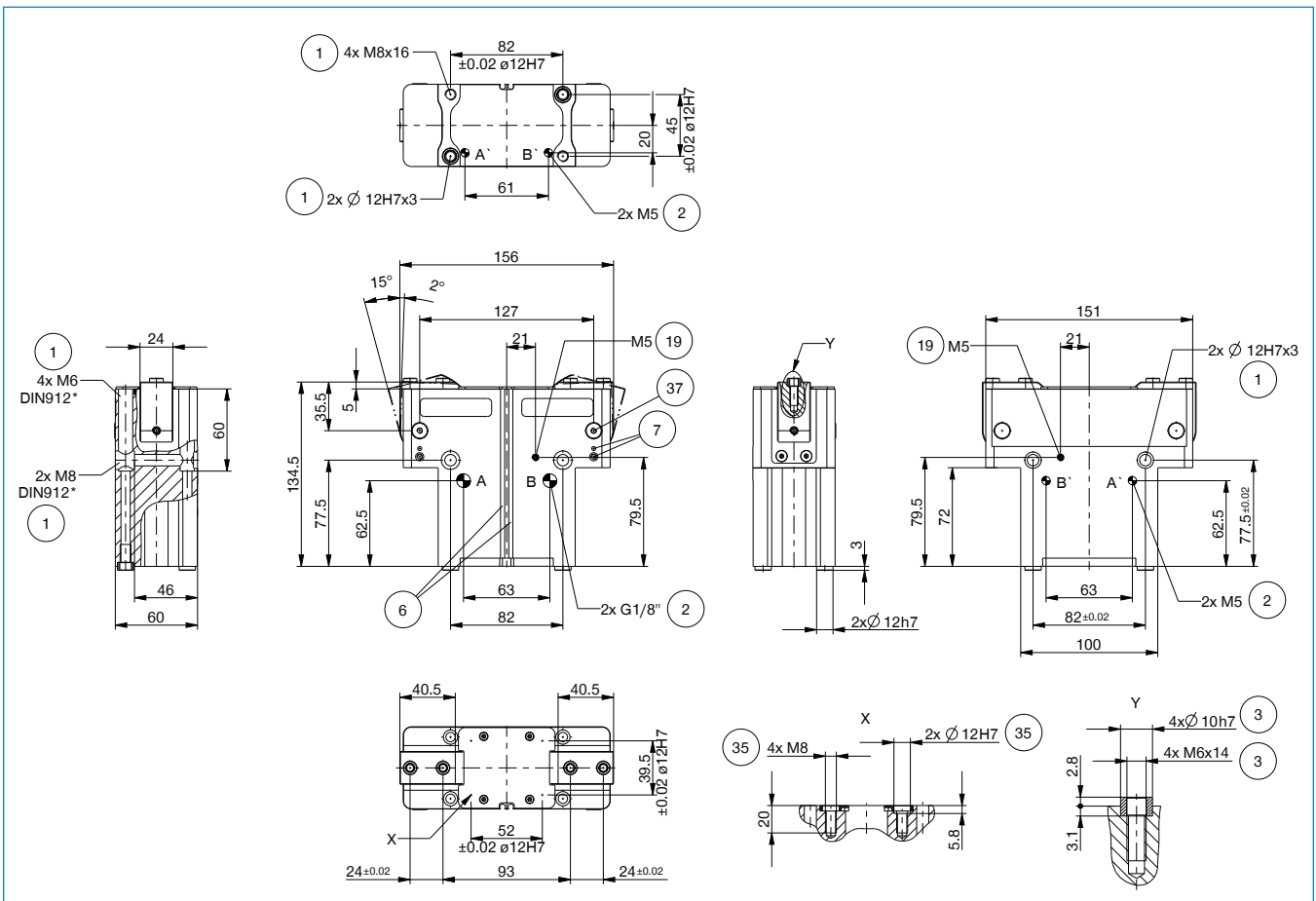

- |  |  |
|--|--|
| ① Gripper attachment                               | ③⑦ Mounting possibility for cam switch |
| ② Energy supply                                    | ③⑧ Adapter                             |
| ③ Fixing for gripper finger                        | ③⑨ Gripper                             |
| ⑥ Integrated slot for magnetic field sensor        | Ⓐ Air connection (close)               |
| ⑦ Fixing for mounting block                        | Ⓑ Air connection (open)                |
| ⑱ Air purge connection option                      | Ⓐ' Air connection, alternative (close) |
| ⑳ Mounting possibility for stroke adjustment screw | Ⓑ' Air connection, alternative (open)  |

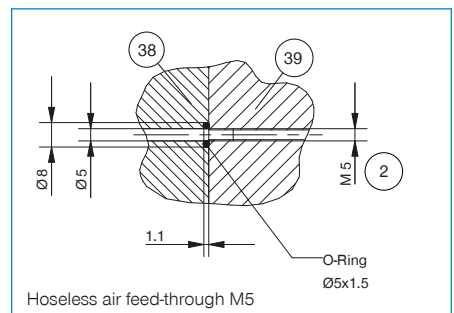

# 2-JAW ANGULAR GRIPPERS

## INSTALLATION SIZE GPW5013

### ▶ ACCESORIES

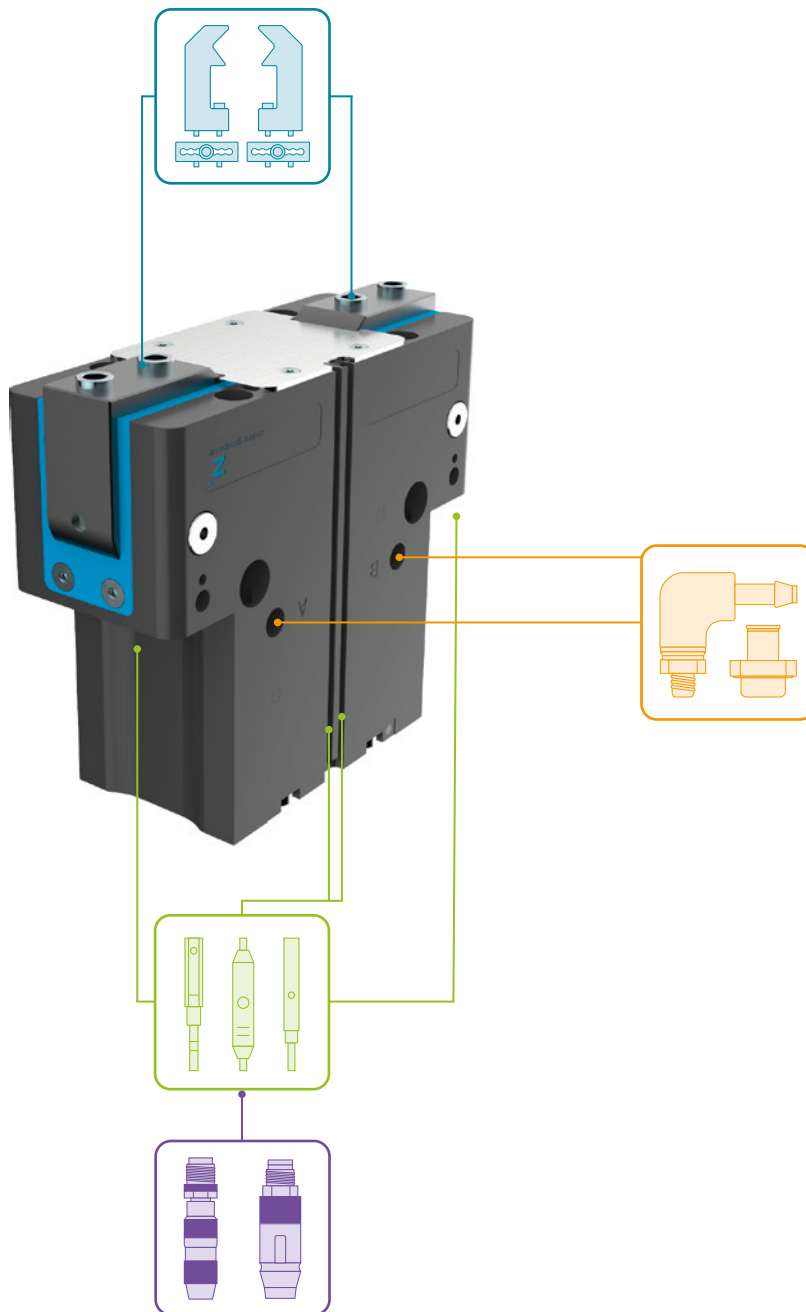

### ▶ INCLUDED IN DELIVERY



4 [piece]  
Centering Disc

018187



2 [piece]  
Centering Disc

019280

## ▶ RECOMMENDED ACCESSORIES



### GRIPPING COMPONENTS

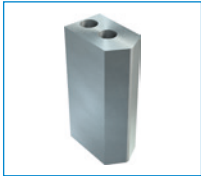

**UB5013AL**  
Universal jaw aluminium



**UB5013ST**  
Universal jaw steel



**EB5013AL**  
Aluminum adjustment jaw



**EB5013ST**  
Steel adjustment jaw



**LB5013**  
L-jaw

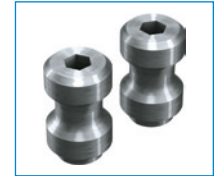

**WB5013L**  
Changeable jaw, loose-part-set



**WB5013F**  
Changeable jaw, fix-part



### ENERGY SUPPLY



**WV1-8X8**  
Angled Fittings - Quick Connect Style



**DSV1-8**  
Pressure safety valve



**DSV1-8E**  
Pressure safety valve with quick exhaust



### SENSORS

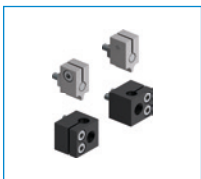

**ANS0084**  
Attachment Kit for Inductive Proximity Switch



**NJ8-E2S**  
Inductive proximity switch - Connector M8



**MFS01-S-KHC-P1-PNP**  
Magnetic field sensor angled, cable 0.3 m - M8 connector



**MFS02-S-KHC-P1-PNP**  
Magnetic field sensor straight, cable 0.3 m - M8 connector



**MFS01-S-KHC-P2-PNP**  
2-point sensor angled, cable 0.3 m - M8 connector



**MFS02-S-KHC-P2-PNP**  
2-point sensor straight, cable 0.3 m - M8 connector



**MFS02-S-KHC-IL**  
Position sensor straight, cable 0.3 m - connector M8

# 2-JAW ANGULAR GRIPPERS

## SERIES GPW5000 FUNCTIONAL DESCRIPTION



### GRIPPING COMPONENTS

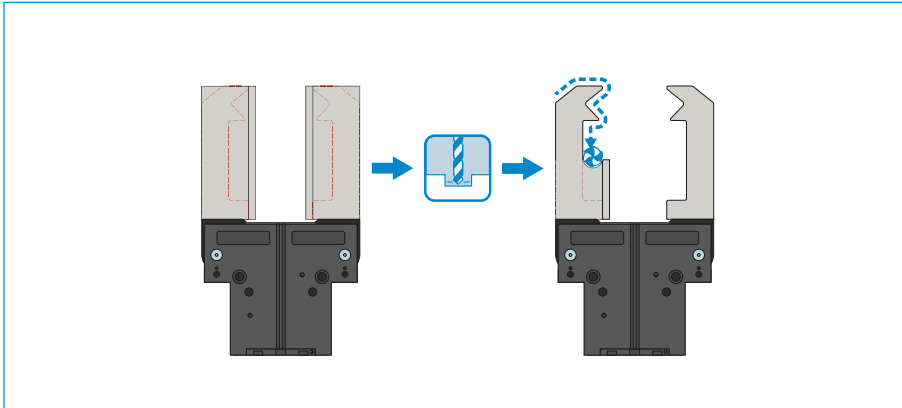

#### Universal jaws – UB5000

Can be used immediately or for individual reprocessing

The gripper blanks are available in aluminum (AL) and steel (ST) versions and are installed directly on the gripper using the screws in the scope of delivery. The fits for the centering sleeves are already in place for this purpose. One universal jaw is required for each gripper jaw.

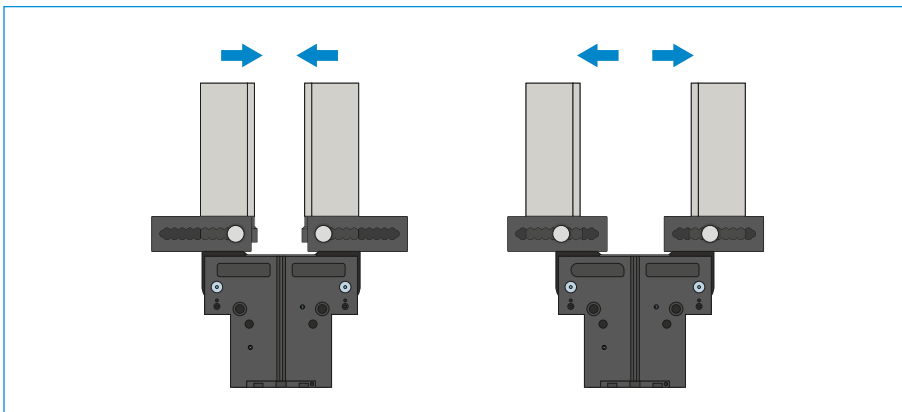

#### Adjustment jaws – EB5000

For tool-free adaptation of the gripper range

By manually activating the locking mechanism, which is pre-tensioned by a spring, the adjustment jaw can be moved within a grid of detent notches that has a number scale. Depending on the forces and torques that apply, the adjustment jaws are available in aluminum (AL) and steel (ST) versions. One adjustment jaw is required for each gripper jaw.

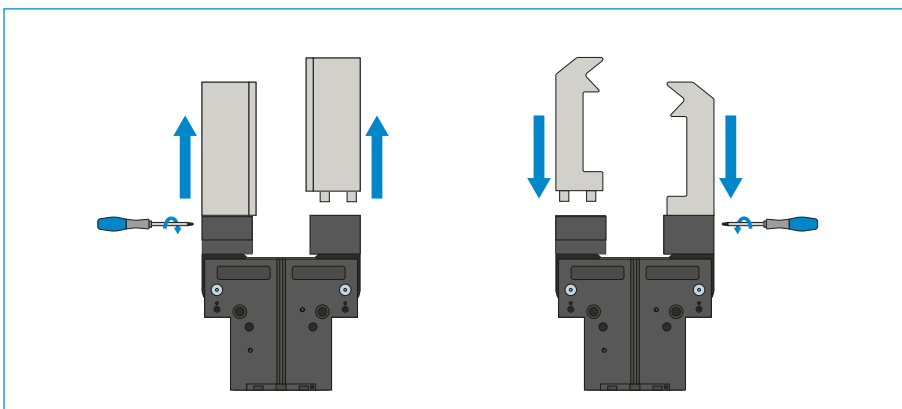

#### Interchangeable jaws – WB5000

Enable fast change of individual gripper fingers

For each gripper jaw, a fixed part and at least one loose part set is needed, depending on the number of gripper fingers to be changed. Manual locking via the Torx wrench included in the scope of delivery of the fixed part can take place from two sides.



## GRIPPING COMPONENTS

### L-gripper jaw – LB5000

Fast and easy method for adapting and installing the gripper fingers on the sides.

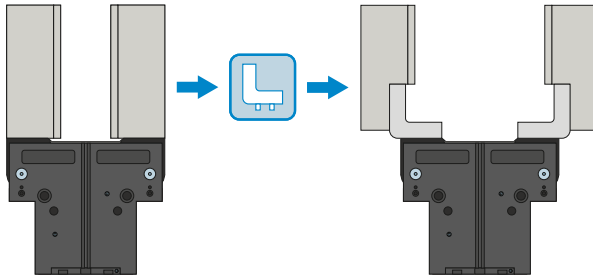

### THE GRIPPING COMPONENTS CAN BE COMBINED!

The gripper components listed above can be combined with each other and are compatible with the various series of the 5000 gripper family.



## ENERGY SUPPLY

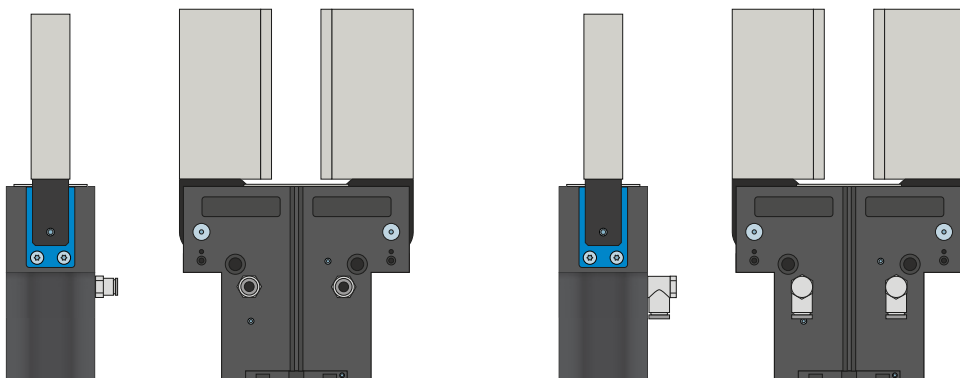

### Pneumatic threaded connections

Available in straight and angled design. Can be chosen freely depending on the space conditions or installation situation.



# 2-JAW ANGULAR GRIPPERS

## SERIES GPW5000 FUNCTIONAL DESCRIPTION



### ENERGY SUPPLY

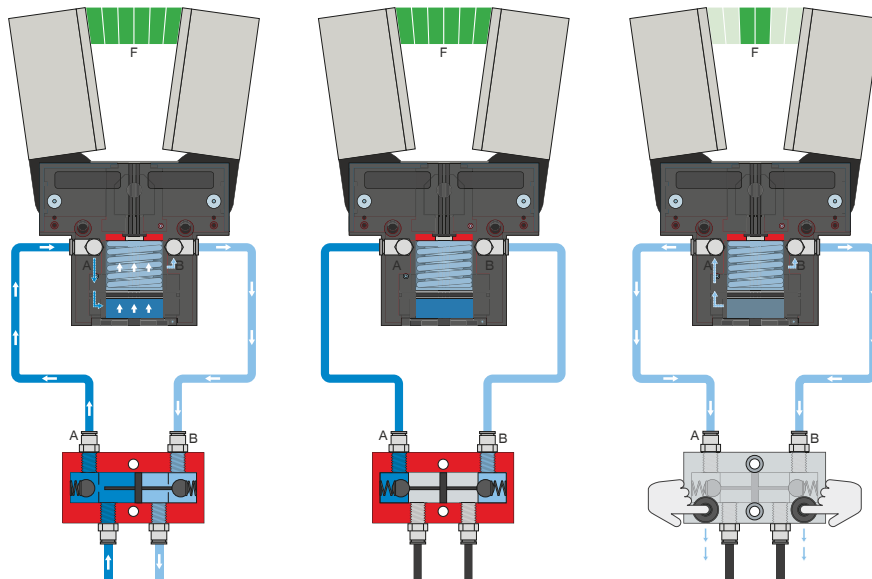

### Pressure safety valve – DSV

Ensures safe retention of force and position if the system pressure drops

The integrated double check valve, which can be unlocked, retains the system pressure of the gripper in case of EMERGENCY STOP. To ensure the function, the valve must be installed as close to the gripper's air connection as possible. In variant E, two pushbuttons are installed that allow for controlled bleeding of the gripper.



### SENSORS

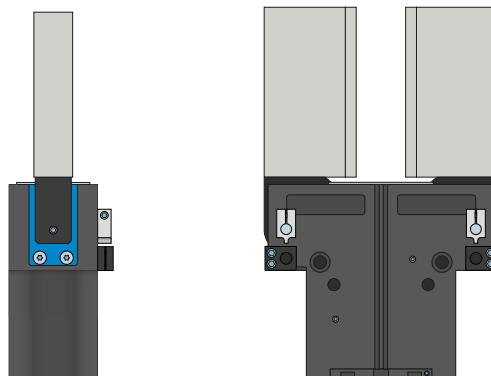

### Attachment kit

The attachment kit is installed on the gripper using the fastening material included in the scope of delivery. The attachment kit enables sensing of the gripper positions via inductive proximity switches.



## SENSORS

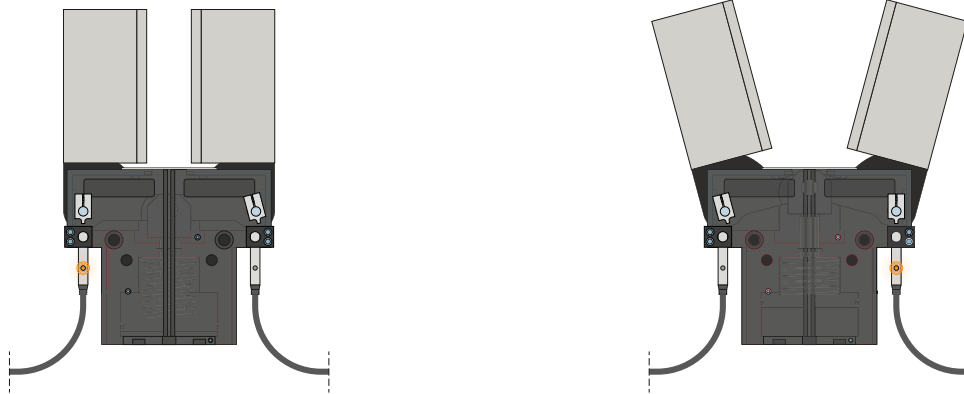

### Inductive sensors – NJ

#### For direct position sensing of the gripper jaws

The sensor is guided into the intake as far as it will go and fixed in place using the lateral clamping screw. Tuning to the desired position then takes place by adjusting the cam switch. The sensors are available in versions with 5 m cables with exposed leads and 0,3 m cable with connector, as well as with direct plug orientation.

# 2-JAW ANGULAR GRIPPERS

## SERIES GPW5000 FUNCTIONAL DESCRIPTION



### SENSORS

MFS02

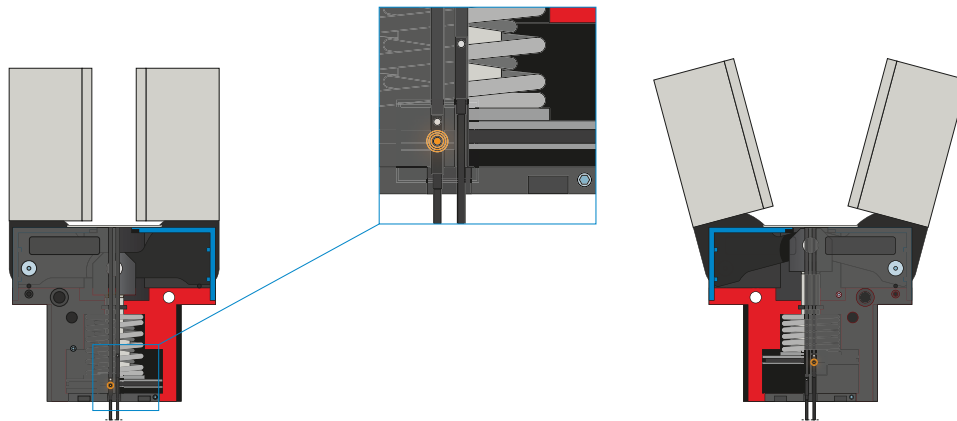

MFS01

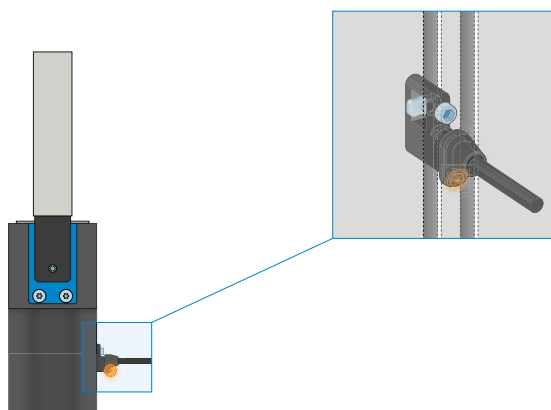

### 1-point magnetic field sensors – MFS

#### For non-contact sensing of the piston position

These sensors are installed in the C-groove of the gripper and detect the magnet attached to the piston of the gripper. To ensure use in a wide variety of space conditions, the sensors are available in two variants. While the horizontal MFS02, with straight cable outlet, disappears into the C-groove of the gripper almost completely, the vertical MFS01 is taller, but has a cable outlet that is offset at an angle of 90°. The variants are available in versions with 5 m cables with exposed leads and 0,3 m cable with connector.



## SENSORS

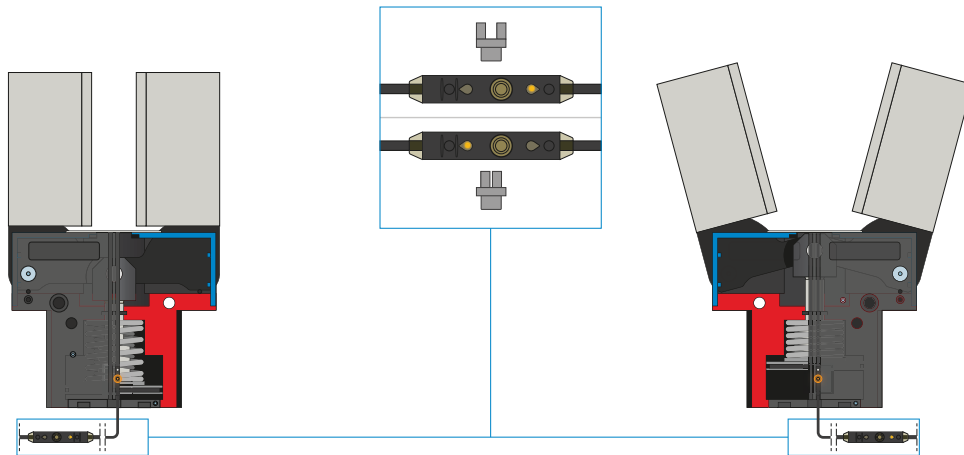

### 2-point magnetic field sensors - MFS

With two freely programmable switching points

Using the programming unit integrated in the cable, two switch points can be freely defined for this sensor. To do so, the sensor is clamped in the C-groove, the gripper approaches position one and the position is taught in using the teach button. Afterwards, the second position is approached with the gripper and programmed. To ensure use in a wide variety of space conditions, the sensors are available in two variants. While the horizontal MFS02, with straight cable outlet, disappears into the C-groove of the gripper almost completely, the vertical MFS01 is taller, but has a cable outlet that is offset at an angle of 90°. The sensors are available in versions with 5 m cables with exposed leads and 0,3 m cable with connector.



## CONNECTIONS / OTHER

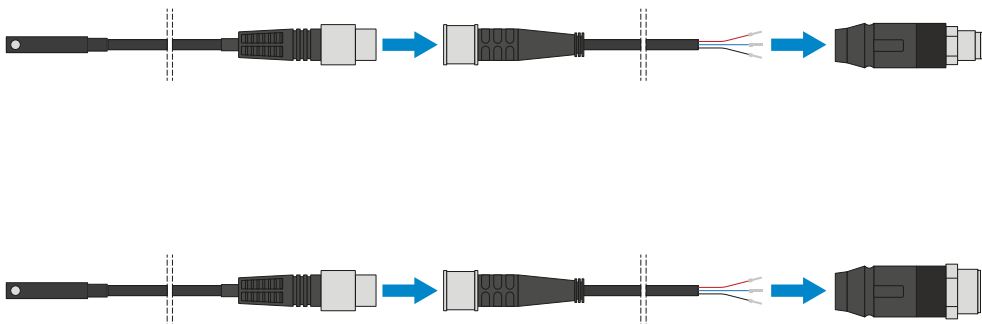

### Plug-in connectors

For extending and fabricating the connection lines for the sensors

Cables with a length of 5 m with exposed leads are available. Depending on the specific needs, the cables can be shortened or fabricated with connectors in sizes M8 and M12.

# 2-JAW ANGULAR GRIPPERS

## SERIES GPW5000 FUNCTIONAL DESCRIPTION



### CONNECTIONS / OTHER

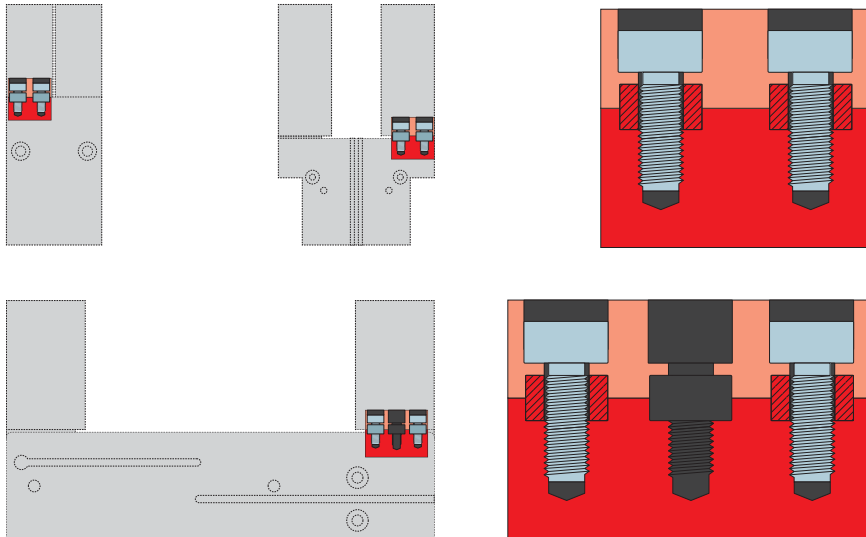

#### Centering sleeves

##### For defined position measurement of the gripper fingers

The centering sleeves are inserted into the fits of the gripper jaws to define the position of the gripper fingers. The centering sleeves are comparable to a pin connection.